



INTRODUCTION

All roof recovering or replacement requires a permit from the Building and Safety Division to ensure compliance with Section 15 of the 2019 California Building Code (CBC), Chapter 9 of the 2019 California Residential Code (CRC), 2019 California Energy Code requirements for Cool Roof Assemblies, City of Calabasas amendments, and the manufacturer's installation instructions.

Permits may be obtained by one of the following methods:

- A licensed and insured C-39 contractor.
- A residential property owner (Owner/Builder) with the proper verification.
- A licensed and insured B contractor (only when the roof is in conjunction with the required multiple trade requirements of the California State License Board).

GENERAL REQUIREMENTS

Building Permits: No roof recovering or replacement work shall start without first obtaining a reroof building permit.

- Roof repairs of less than 10% of the roof area or 200 square feet (whichever is less) may be done *without a permit* provided the damaged portion is replaced to its previous undamaged condition.
- If the work is more than 10% --but less than 50% -- of the roof, a permit is required and the roof recovering or replacement work portion shall meet current code while the remaining roof may stay in its current condition.
- If the work is over 50% of the roof, a permit is required and the entire roof must meet current code.

Fire-Protection: New roof coverings shall comply with the following:

- All roof coverings shall have a minimum Class "A" Rating. (R902.1.1)
- Wood shakes and wood shingles (fire treated or untreated) are not allowed in the City of Calabasas.

Roof Recovering: A roof re-cover shall not be permitted where any of the following conditions occur: (R908.3.1.1)

- Where the existing roof or roof covering is water soaked or has deteriorated to the point that the existing roof or roof covering is not adequate as a base for additional roofing.
- Where the existing roof covering is slate, clay, cement or asbestos-cement tile.
- Where the existing roof has two or more applications of any type of roof covering.

Reinstallation of Materials: Existing slate, clay, or cement tile will be permitted for reinstallation, except that damaged, cracked or broken slate or tile shall not be reinstalled. Existing vent flashing, metal edgings, drain outlets, collars, and metal counter-flashings shall be replaced where rusted, damaged, or deteriorated. Aggregate surfacing materials shall not be reinstalled. (CRC section 908.5)

Structural Issues: A licensed engineer or architect may be required to prepare structural calculations and/or plans, when the following condition occurs:

- When the weight of the new roof covering and the existing roof covering (when not removed) or the new roof covering itself (when the existing roof is removed), exceeds 7 pounds per square foot.



- When the weight of the new roof replacement exceeds the weight of the removed existing roof.

NOTE: The weight of new wood structural panel sheathing over existing board decking must be included in the 7 pounds per square foot maximum. 15/32" plywood is about 1.5 pounds per square foot.

Flashings: Flashings shall be reconstructed in accordance with approved manufacturer's installation instructions. Metal flashing to which bituminous materials are to be adhered shall be primed prior to installation (R908.6).

EXISTING BOARD DECKING AND PANEL SHEATHING INSTALLATION

Where solid, diagonal, or spaced board decking is encountered, new wood structural panel sheathing shall be installed over the existing board decking or the existing board decking shall be removed without causing structural damage. If the existing board decking is removed, new wood structural panel sheathing is added over the existing board decking, it shall be included in the total weight of the roof.

- Panel sheathing shall be 5/8" minimum thickness CDX grade plywood or exterior grade OSB.
- For panel sheathing over existing 1x board decking, use 10d at 6"/6"/12" on center. For panel sheathing over existing 2x board decking, use 16d at 6"/6"/12" on center. See "Detail A" below.
- Lay panel sheathing perpendicular to rafter supports. For edges parallel to the board decking, a 1 1/2 minimum lap onto the board decking shall be maintained. Minimum panel sheathing shall not be less than 2 feet in width and must span over minimum of three joist spaces.

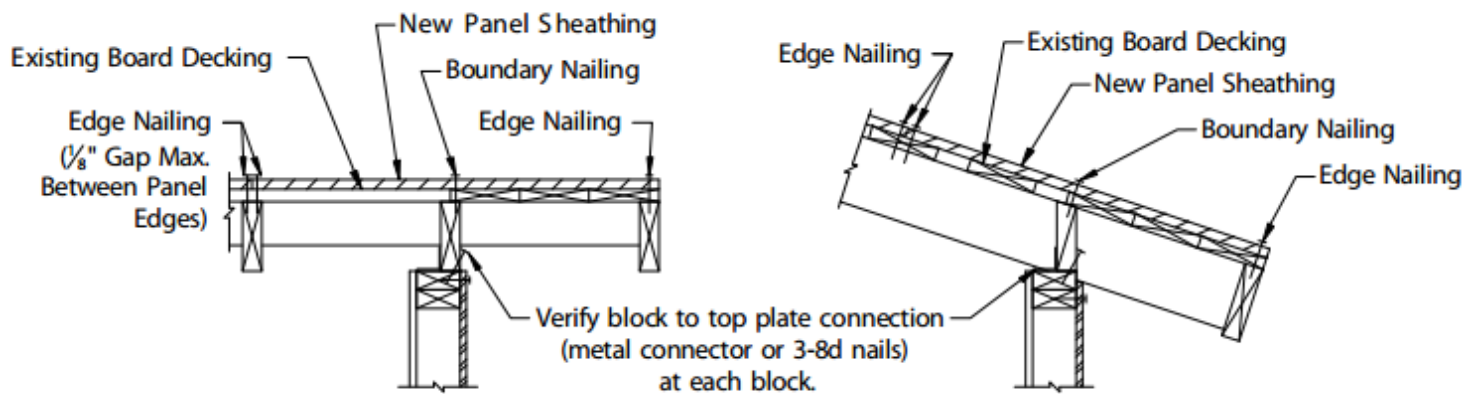

ROOFING MATERIAL

Composition shingles: New composition shingles may be installed directly on existing roof coverings if the existing is in reasonably sound condition. The existing roof coverings may not be wood shakes, wood shingles, slate, clay, or asbestos cement tiles. A maximum of two layers of composition shingles may be allowed on a roof. Curled edges need to be removed.

Wood Shingles/Wood shakes: Wood shingles and wood shakes (fire treated or untreated) are not permitted for use in the City of Calabasas.



Tile Roofing: The roofing shall be installed directly on wood structural panel sheathing. If the weight of the new tile is more than 7 pounds per square foot or heavier than the existing tile, a licensed engineer or architect may be required to prepare structural calculations and/or plans. If board decking is encountered, panel sheathing must be placed over the board decking or the existing board decking removed and replaced with panel sheathing. When panel sheathing is installed over board decking, the weight of the panel sheathing must be included in the maximum weight of 7 pounds per square foot.

Cap Sheet: New cap sheets may be installed directly on existing residential roof coverings if the existing is in reasonably sound condition. The existing residential roof coverings may not be wood shakes, wood shingles, slate, clay, or asbestos cement tiles. A maximum of two layers of cap sheets may be allowed on a residential roof. A maximum of one layer of cap sheets may be installed on a commercial roof in addition to scheduling a pre-inspection.

INSPECTIONS

Roof Sheathing Inspection: A roof sheathing inspection is required for all roof recovery and replacement work upon removal of all existing layers of roof coverings or, where the existing roof covering is to be recovered, prior to the installation of the new felt, paper, or roofing material, to verify that the roof structure is not damaged or dry rotted. Prior to such inspections, any damaged areas of the roof deck or structural framing members shall be repaired and/or replaced with new material.

Final Inspection: Approval shall be obtained when roof recovering or replacement work is complete. At this time the inspector will verify the flashing and proper lap.

- **A ladder shall be onsite** at the time of inspection. The ladder shall have a minimum 300 lb. Duty Rating (Type IA) and be long enough to extend two feet above the roofline.
- The contractor/homeowner is responsible for extending all plumbing vents, chimney, and mechanical vents if needed. (Section 906.0-906.7 California Plumbing Code and Sections 802.2 – 802.6 California Mechanical Code).
- The contractor/homeowner is responsible for ensuring the proper amount of attic ventilation is installed per CRC Section R806.

INSPECTION PHONE LINE

The inspection phone line is **(818)224-1738** and is available 24 hours/day. Inspection requests received after 7:00 a.m. will be scheduled for the following business day.

On line inspection request:

<http://www.cityofcalabasas.com/BuildingSafety/inspection-requests.html>