



CITY of CALABASAS

Community Development Department  
Planning Division  
100 Civic Center Way  
Calabasas, CA 91302  
T: 818.224.1600

[www.cityofcalabasas.com](http://www.cityofcalabasas.com)

February 17, 2021

Synergy – a division of Advantage Engineers  
Attn: Luke Snyder  
7543 Woodley Ave  
Van Nuys, CA 91406

**Subject: Notice of Decision for Project No. WTFM-2020-009**

Dear Mr. Snyder,

At a public hearing on February 17, 2021, the Community Development Director considered testimony given, reviewed the staff report and other documents and materials in the project file, and, based upon the findings presented in the staff report, **APPROVED** your application for the following:

**FILE NO.: WTFM-2020-009.** A request for a Wireless Telecommunication Facility Minor Modification Permit to modify an existing T-Mobile wireless telecommunication facility in accordance with Section 6409(a) of the 2012 tax relief act. The applicant is proposing to install new pole-mounted equipment, painted to match the existing pole. The project is located on a wood utility pole at 24401 ½ Mulholland Hwy, within the Public Right-of-Way

Your application, described above, is subject to all conditions of approval listed in the attached Exhibit A. Any decision of the Community Development Department may be appealed to the Planning Commission. Appeals must be submitted in writing to the City Clerk (per Chapter 17.74 of the Calabasas Municipal Code) within ten (10) days of the Community Development Director action.

Should you have any questions concerning this application, please contact me at (818) 224-1705 or [jrackerby@cityofcalabasas.com](mailto:jrackerby@cityofcalabasas.com).

Sincerely,



Jaclyn Rackerby  
Assistant Planner

Attachment: Community Development Director Decision Letter and Report



CITY of CALABASAS

## COMMUNITY DEVELOPMENT DIRECTOR DECISION LETTER AND REPORT

---

**FILE NO.:** WTFM-2020-009

**PROPOSAL:** A request for a Wireless Telecommunication Facility Minor Modification Permit to modify an existing T-Mobile wireless telecommunication facility in accordance with Section 6409(a) of the 2012 tax relief act. The applicant is proposing to install new pole-mounted equipment, painted to match the existing pole. The project is located on a wood utility pole at 24401 ½ Mulholland Hwy, within the Public Right-of-Way.

**APPLICANT:** Luke Snyder, Synergy – a division of Advantage Engineers

---

### **BACKGROUND:**

On October 13, 2020, Synergy – a division of Advantage Engineers filed an application, on behalf of T-mobile, to upgrade an existing wireless telecommunication facility located at 24401 ½ Mulholland Hwy, located in the Public Right-of-Way. The application was reviewed by staff and deemed complete on February 4, 2021.

The existing T-mobile facility was approved in November 1999 (approved Minor Development Permit No. 99-01).

The proposed project includes the installation of two new pole-mounted equipment cabinets. This project was reviewed by the Telecom Law Firm for concurrence that the project is an eligible facility request under Section 6409(a) of the Middle Class Tax Relief and Job Creation Act of 2012 (the Act) applies. In a Wireless Telecommunication Memorandum dated February 3, 2021 (Exhibit D), Jonathan Kramer of the Telecom Law Firm stated that the proposed project meets all of the criteria necessary to be eligible for Section 6409(a).

### **STAFF ANALYSIS:**

1. **Current Site Condition:** The subject site is located at 24401 ½ Mulholland Hwy within the public right-of-way, approximately 650 feet south of the intersection at Turtle Creek Rd and Mulholland Hwy. The existing facility was approved in November 1999. The current facility is made up of two antennas mounted to an antenna arm located on a utility pole, with equipment painted brown to match the existing pole.
2. **Proposed Project:** The applicant is requesting permission to upgrade an existing Wireless Telecommunications Facility in accordance with Section 6409(a) of the 2012 Tax Relief Act. The proposal includes the installation of additional pole-

mounted cabinets. All proposed equipment will be painted to match the existing pole.

3. Calabasas Municipal Code Requirements: Section 17.12.050 of the CMC regulates the construction, maintenance, and modification of wireless telecommunication facilities within the City of Calabasas. In accordance with Section 17.12.050(B) (4) of the CMC, the ordinance applies to existing facilities which have been previously approved but are now or hereafter modified. Section 17.12.050(F) of the CMC regulates minor modifications of existing facilities that are an eligible facilities request, consistent with Section 6409(A) of the Middle Class Tax Relief and Job Creation Act of 2012. As a result, the applicant has filed for a Minor Modification Permit to perform the requested equipment additions.
4. Section 6409(A) Analysis: On February 17, 2012, Congress passed the "Middle Class Tax Relief and Job Creation Act of 2012" (the "Act"). Section 6409(a) of the Act states that "a State or local government may not deny, and shall approve, any eligible facilities request for a modification of an existing wireless tower or base station that does not substantially change the physical dimensions of such tower or base station." Eligible facilities include requests that involve: (a) collocation of new transmission equipment, (b) removal of transmission equipment; or (c) replacement of transmission equipment. Because the proposed project involves the installation of new pole mounted equipment, it qualifies as an eligible facility under the Act. Finally, the proposed project will not substantially change the physical dimensions of the existing tower or base station. As a result, section 6409(a) of the Act applies to the proposed project, and the City shall approve and may not deny this application. Consequently, the project meets all requirements for approval of a Minor Modification Permit and Section 6409(a).

### **FINDINGS:**

Section 17.12.050(F)(5)(c) stipulates that the Director must approve an application for a wireless facility minor modification permit for a collocation or modification to an existing tower or base station within the public right-of-way, only if each of the following findings can be made:

1. *The applicant proposes a collocation or modification to a structure constructed and maintained with all necessary permits in good standing, whether built for the sole or primary purpose of supporting any Federal Communications Commission licensed or authorized antennas and their associated facilities or not, that currently supports existing wireless transmission equipment;*

The proposed project involves the installation of two new cabinets mounted to an existing utility pole. The site was recently inspected by staff, and found to be in good condition (i.e. no graffiti, and no damage to the utility pole or equipment) and in compliance with all conditions of approval contained within Minor Development Permit

No. 99-01, which is the most recently approved project for this facility. As a result, the proposed project meets this finding.

2. *The proposed collocation or modification does not increase the height of the existing personal wireless telecommunication facility above its lowest height on February 22, 2012, or as approved if constructed after February 22, 2012, by more than ten (10) percent or ten (10) feet, whichever is greater;*

The modifications to the base station involve the installation of pole-mounted equipment cabinets. The existing facility will not increase in height; therefore, this finding is met.

3. *The proposed collocation or modification does not increase the width of the facility by more than six (6) feet;*

The extent of the modifications to the base station is the installation of two pole-mounted equipment cabinets. The proposed project involves no increase in the width of the existing facility, and this finding is met.

4. *The proposed collocation or modification does not involve the installation of more than the standard number of new equipment cabinets for the technology involved, not to exceed four (4);*

The modifications to the base station involve the installation of two new equipment cabinets. This does not exceed the FCC's equipment cabinet threshold of four cabinets. Therefore, the proposed project meets this finding.

5. *The proposed collocation or modification does not involve either (i) the installation of any new equipment cabinets on the ground, if none already exist, or (ii) the installation of ground equipment cabinets that are more than ten (10) percent larger in height or overall volume than any existing ground cabinets;*

The proposed project does not involve the installation of any new ground-mounted equipment, only the installation of pole mounted equipment cabinets. Therefore, the proposed project meets this finding.

6. *The proposed collocation or modification does not involve any excavation outside the area in proximity to the existing ground-mounted equipment in the public right-of-way;*

The proposed modifications to install new equipment cabinets for the wireless facility is entirely mounted to the existing utility pole, and does not involve any ground disturbance. Therefore, the proposed project meets this finding.

7. *The proposed collocation or modification does not defeat any existing concealment elements of the existing structure; and*

The existing wireless facility utilizes brown paint as a concealment measure to ensure all equipment matches the existing pole. The proposed equipment cabinets will utilize the same concealment measures, and will be painted brown to match the pole. For this reason, the proposed project satisfies this finding.

8. *The proposed collocation or modification does not violate any prior conditions of approval, except as may be preempted by Section 6409, Title 47, United States Code, section 1455, subdivision (a).*

Upon a site visit by City staff, it was determined that the existing wireless facility was constructed and remained in compliance with the approved plans and conditions of approval contained within the latest approved project, (Minor Development Permit No. 99-01). Therefore, the proposed project meets this finding.

#### **ENVIRONMENTAL REVIEW:**

The City's staff has determined that the project is exempt from environmental review in accordance with Section 21084 of the California Environmental Quality Act (CEQA) and Section 15301 (Existing Facilities) of the CEQA Guidelines.

**CONDITIONS OF APPROVAL:**

See the attached conditions in Exhibit A.

I have read and agree to the indemnification agreement and attached conditions of approval listed in Exhibit A.



Applicant/Carrier Representative

2/22/21  
Date

**DECISION:**

The Director or his/her designee has considered all of the evidence submitted into the administrative record including, but not limited to:

1. All applicable codes and regulations including the City of Calabasas Land Use and Development Code and the City's General Plan;
2. Plans provided by the applicant, as well as any written information; and
3. All related documents, including any necessary environmental documents in order to comply with the California Environmental Quality Act (CEQA), received and/or submitted to the Department.

After considering all of the evidence submitted into the administrative record listed above, I hereby make the following decision:

Approved                       Denied

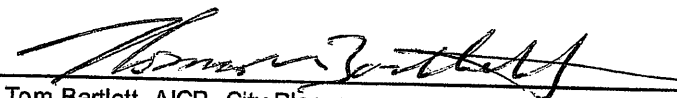

Tom Bartlett, AICP, City Planner

Feb 17, 2021  
Date

**ATTACHMENTS:**

- Exhibit A: Conditions of Approval
- Exhibit B: Public Hearing Record
- Exhibit C: Project Plans
- Exhibit D: Memo from Telecom Law Firm



CITY of CALABASAS

**COMMUNITY DEVELOPMENT DIRECTOR  
DECISION LETTER AND REPORT**

**EXHIBIT A: CONDITIONS OF APPROVAL**

---

**FILE NO.:** WTFM-2020-009  
**PROPOSAL:** A request for a Wireless Telecommunication Facility Minor Modification Permit to modify an existing T-Mobile wireless telecommunication facility in accordance with Section 6409(a) of the 2012 tax relief act. The applicant is proposing to install new pole-mounted equipment, painted to match the existing pole. The project is located on a wood utility pole at 24401 ½ Mulholland Hwy, within the Public Right-of-Way.  
**APPLICANT:** Luke Snyder, Synergy - a division of Advantage Engineers

---

1. The City has determined that City, its employees, agents, and officials should, to the fullest extent permitted by law, be fully protected from any loss, injury, damage, claim, lawsuit, expense, attorney fees, litigation expenses, court costs or any other costs arising out of or in any way related to this File No. WTFM-2020-009 and the issuance of any permit or entitlement in connection therewith, or the activities conducted pursuant to this File No WTFM-2020-009 and the issuance of any permit or entitlement in connection therewith. Accordingly, to the fullest extent permitted by law, Synergy – a division of Advantage Engineers (applicant) and T-Mobile (carrier), and their successors shall defend, indemnify and hold harmless City, its employees, agents and officials, from and against any liability, claims, suits, actions, arbitration proceedings, regulatory proceedings, losses, expenses or costs of any kind, whether actual, alleged or threatened, including, but not limited to, actual attorney fees, litigation expenses and court costs of any kind without restriction or limitation, incurred in relation to, as a consequence of, arising out of or in any way attributable to, actually, allegedly or impliedly, in whole or in part, related to this File No. WTFM-2020-009 and the issuance of any permit or entitlement in connection therewith, or the activities conducted pursuant to this File No. WTFM-2020-009 and the issuance of any permit or entitlement in connection therewith Synergy – a division of Advantage Engineers (applicant) and T-Mobile (carrier), and their successors shall pay such obligations as they are incurred by City, its employees, agents and officials, and in the event of any claim or lawsuit, shall submit a deposit in such amount as the City reasonably determines necessary to protect the City from exposure to fees, costs or liability with respect to such claim or lawsuit.
2. Compliance with approved plans. The proposed project shall be built in compliance with the approved plans on file with the Planning Division.

3. The project approved herein is depicted on those sets of drawings, elevations, etc., stamped approved by staff on the approval date. Any modifications to these plans must be approved by the Community Development Director prior to the changes on the working drawings or in the field.
4. The subject property shall be developed, maintained, and operated in full compliance with the conditions of this grant and any law, statute, ordinance or other regulation applicable to any development or activity on the subject property. Failure of the applicant or its successors to cease any development or activity not in full compliance shall be a violation of these conditions. Any violation of the conditions of approval may result in the revocation of this approval.
5. This approval shall be valid for one year and eleven days from the date of this decision letter. The permit may be extended in accordance with Section 17.64.050 of the Land Use and Development Code.
6. Prior to commencement of construction, all necessary permits shall be obtained from the Building and Safety Division and Public Works Department.
7. The project is located within a designated "Very High Fire Hazard Severity Zone". The requirements of Chapter 64 of the 2010 Los Angeles County Building Code, Vol. 1, must be incorporated into all plans.
8. The applicant and contractors shall implement all reasonable efforts to reuse and recycle construction and demolition debris, to use environmentally friendly materials, and to provide energy efficient buildings, equipment, and systems. The applicant shall provide proof of recycling quantities to get final clearance of occupancy.
9. Per the Calabasas Municipal Code Chapter 8.16, "no person shall collect and/or dispose of municipal solid waste or recyclable materials in the city without having first been issued a solid waste collection permit. Such permit shall be in addition to any business license or permit otherwise required by the City of Calabasas." Please contact the Public Works Department for a list of permitted haulers. An Encroachment Permit is required prior to placing a refuse bin/container on the street.
10. Construction Activities - Hours of construction activity shall be limited to:
  - i. 9:00 a.m. to 2:00 p.m., Monday through Friday
  - ii. 8:00 a.m. to 5:00 p.m., Saturday

Stacking of construction worker vehicles, prior to 7:00 a.m. in the morning will be restricted to areas that do not adversely affect adjacent residences or schools.



The applicant or its successors shall notify the Public Works Director of the construction employee parking locations, prior to commencement of construction.

11. No new antenna, or additional equipment not included or specified in the stamped approved plans may be installed on the subject site under this permit.
12. No automatic renewal. The grant or approval of a wireless facility minor modification permit shall not renew or extend the underlying permit term.
13. Compliance with previous approvals. The grant or approval of a wireless facility minor modification permit shall be subject to the conditions of approval of the underlying permit, except as may be preempted by Section 6409, subdivision (a).
14. The applicant shall submit to the director an as-built set of plans and photographs depicting the entire personal wireless telecommunications facility as modified, including all transmission equipment and all utilities, within ninety (90) days after the completion of construction.
15. Indemnification. To the fullest extent permitted by law, the applicant and any successors and assigns, shall defend, indemnify and hold harmless City, its employees, agents and officials, from and against any liability, claims, suits, actions, arbitration proceedings, regulatory proceedings, losses, expenses or costs of any kind, whether actual, alleged or threatened, including, but not limited to, actual attorney fees, litigation expenses and court costs of any kind without restriction or limitation, incurred in relation to, as a consequence of, arising out of or in any way attributable to, actually, allegedly or impliedly, in whole or in part, related to the wireless facility minor modification permit and the issuance of any permit or entitlement in connection therewith. The applicant shall pay such obligations as they are incurred by City, its employees, agents and officials, and in the event of any claim or lawsuit, shall submit a deposit in such amount as the City reasonably determines necessary to protect the City from exposure to fees, costs or liability with respect to such claim or lawsuit.
16. The applicant shall comply with all applicable provisions of this Code, any permit issued under this Code, and all other applicable federal, state, and local laws. Any failure by the City to enforce compliance with any applicable laws shall not relieve any applicant of its obligations under this code, any permit issued under this code, or all other applicable laws and regulations.
17. The facility shall be developed, maintained, and operated in full compliance with the conditions of the wireless facility minor modification permit, any other applicable permit, and any law, statute, ordinance or other regulation applicable to any development or activity on the site. Failure of the applicant to cease any development or activity not in full compliance shall be a violation of these conditions. Any violation of this Code, the conditions of approval for the wireless facility minor modification permit, or any other law, statute, ordinance or other

regulation applicable to any development or activity on the site may result in the revocation of this permit. The remedies specified in this section shall be cumulative and the city may resort to any other remedy available at law or in equity and resort to any one remedy shall not cause an election precluding the use of any other remedy with respect to a violation.

18. Proposed cabinets shall utilize the site's existing concealment measure of brown paint to match existing equipment and wood utility pole.
19. In the event that a court of competent jurisdiction invalidates or limits, in part or in whole, Title 47, United States Code, section 1455, such that such statute would not mandate approval for the collocation or modification granted or deemed granted under a wireless facility minor modification permit, such permit shall automatically expire twelve (12) months from the date of that opinion.
20. The grant, deemed-grant or acceptance of wireless facility minor modification permit shall not waive and shall not be construed or deemed to waive the City's standing in a court of competent jurisdiction to challenge Title 47, United States Code, section 1455 or any wireless facility minor modification permit issued pursuant to Title 47, United States Code, section 1455 or this code.
21. Permittee shall ensure that all federally-required radio frequency signage be installed and maintained at all times in good condition. All such radio frequency signage be constructed of hard materials and be UV stabilized. All radio frequency signage must comply with the sign colors, sign sizes, sign symbols, and sign panel layouts in conformance with the most current versions of ANSI Z535.1, ANSI Z535.2, and ANSI C95.2 standards. All such radio frequency signage, or additional signage immediately adjacent to the radio frequency signage, shall provide a working local or toll-free telephone number to its network operations center that reaches a live person who can exert transmitter power-down control over this site as required by the FCC.
22. In the event that the FCC changes any of radio frequency signage requirements that are applicable to the project site approved herein or ANSI Z535.1, ANSI Z535.2, and ANSI C95.2 standards that are applicable to the project site approved herein are changed, Permittee, within 30 days of each such change, at its own cost and expense, shall replace the signage at the project site to comply with the then current standards.



CITY of CALABASAS

**COMMUNITY DEVELOPMENT DEPARTMENT  
DECISION LETTER AND REPORT**

**EXHIBIT B: PUBLIC HEARING RECORD**

---

**FILE NO.:** WTFM-2020-009  
**PROPOSAL:** A request for a Wireless Telecommunication Facility Minor Modification Permit to modify an existing T-Mobile wireless telecommunication facility in accordance with Section 6409(a) of the 2012 tax relief act. The applicant is proposing to install new pole-mounted equipment, painted to match the existing pole. The project is located on a wood utility pole at 24401 ½ Mulholland Hwy, within the Public Right-of-Way.  
**APPLICANT:** Luke Snyder, Synergy - a division of Advantage Engineers

---

1. On Wednesday, February 17, 2021, 2:00 P.M. City Planner Tom Bartlett held the duly noticed public meeting via Zoom;
2. Jaclyn Rackerby, Assistant Planner presented the staff report for the project, which included the staff recommendation to approve the project. Following the staff report the designee of the Director, City Planner Tom Bartlett, opened the public hearing;
3. The applicant spoke in favor of the project.
4. With there being no other persons to present testimony regarding the application, the public hearing was closed.
5. The City Planner announced the decision as Approved.

## WIRELESS PLANNING MEMORANDUM

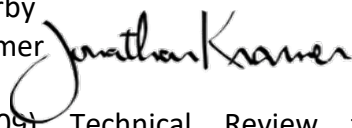
**TO:** Ms. Jaclyn Rackerby  
**FROM:** Dr. Jonathan Kramer   
**DATE:** February 3, 2020  
**RE:** (WTFM 2020-009) Technical Review for Proposed Modifications to Existing Wireless Site located near 24401½ Mulholland Highway Submitted for Approval Under 47 U.S.C. § 1455(a)

**Applicant:** Synergy Engineering Services  
**Carrier:** T-Mobile West, LLC  
**Site Name:** LA872 Mulholland Hwy

### 1. Summary

The City of Calabasas (the “**City**”) requested that Telecom Law Firm, PC (“**TLF**”) review the Synergy Engineering Services, a division of Advantage Engineering (“the **Applicant**”) application submitted on behalf of T-Mobile West, LLC (“**T-Mobile**”) to modify its existing wireless site located near 24401 ½ Mulholland Highway.

The project appears to fall within the scope of Section 6409(a). This is because T-Mobile’s proposal appears to be an eligible facility which does not cause a substantial change, therefore the overall shot clock for this project is 60 calendar days.

T-Mobile has submitted a compliance statement for the proposed modification to its existing wireless facility stating that it will be in planned compliance with the FCC RF emissions guidelines. The statement was submitted under the penalty of perjury. The City should issue any permit approval for this project to be subject to the submittal of an affirmation of FCC compliance based on the Calabasas Municipal Code (“**CMC**”) §17.12.050.

This memorandum reviews the application and related materials for technical and regulatory issues specific to wireless infrastructure. Although many technical issues implicate legal issues, the analysis and recommendations contained in this memorandum do not constitute legal advice.

### 2. Project Background and Description

T-Mobile requests approval to modify its existing wireless site pursuant to Section 6409(a) of the Middle Class Tax Relief and Job Creation Act of 2012.<sup>1</sup> Accordingly, this memorandum focuses its review to the initial questions: (1) whether Section 6409(a) applies to this proposal, and (2)

---

<sup>1</sup> See Section 6409(a) of the Middle-Class Tax Relief and Job Creation Act of 2012, Pub. L. No. 112-96, 126 Stat. 156. (Feb. 22, 2012) (codified as 47 U.S.C. § 1455(a)).

whether the project demonstrates planned compliance with the FCC’s radio frequency exposure guidelines.

On October 13, 2020, the Applicant submitted application materials (“**October 2020 Submission**”) that proposed to modify T-Mobile’s existing wireless site by removing and replacing the antennas mounted to a 52’ above ground level (“**AGL**”) wood utility pole (“**Pole**”).

On November 6, 2020, the City submitted a timely incomplete letter (the “**First City Incomplete Letter**”) that evaluated the Applicant’s October 2020 Submission.

On December 10, 2020, the Applicant submitted additional materials (“**the December 2020 Submission**”) to address the deficiencies identified in the First City Incomplete Letter.

On December 11, 2020, the City submitted a timely incomplete letter (the “**Second City Incomplete Letter**”) that evaluated the Applicant’s December 2020 Submission.

On January 15, 2021, the Applicant submitted additional materials (“**January 2021 Submission**”) to address the deficiencies identified in the Second City Incomplete Letter.

This memorandum reviews the Applicant’s January 2021 Submission application materials to (1) provide the City further analysis on whether the Applicant submitted a complete and responsive application (2) whether Section 6409(a) applies to T-Mobile’s proposal; and (3) whether the proposal demonstrates planned compliance with the federal radio frequency exposure guidelines.

The January 2021 Submission contained revised project plans dated January 15, 2021 (“**Plans**”) that show the proposed installation of a large Emerson cabinet, one Ciena cabinet and PVC risers on the Pole. The Emerson cabinet will contain one AC outlet, one AC/DC power inverter RMF 1048 and one car-router. For a summary of the project, see the description from the Plans in Figure 1.

PROJECT DESCRIPTION
<p>SCOPE OF WORK:</p> <p>SCOPE OF WORK WILL CONSIST OF THE FOLLOWING:</p> <p>PLACING (1) CIENA CAB ON A DOUBLE BACKPLATE</p> <p>PLACE (1) 6-FIBER TERMINAL (PLACED BY AT&amp;T)</p> <p>PLACE (1) DURA-COMM</p> <p>PLACE (1) LARGE EMERSON CABINET. NEEDS AN AC OUTLET INSIDE THE EMERSON CABINET FOR CIENA AND AC/DC POWER INVERTER RMF 1048 IS NEEDED INSIDE THE AAV CABINET/PLACE NEW CAR ROUTER IN AAV CAB.</p> <p>GC TO SUPPLY AND INSTALL (1) DBL. BACKPLATE</p> <p>GC TO PREP SITE FOR AT&amp;T TELCO</p> <p>GC TO SUPPLY AND INSTALL (1) GMT FUSE PANEL</p> <p>GC TO INSTALL (1)2" PVC SCH 80 CONDUIT FROM EMERSON CABINET TO COMMS LINE WITH WEATHERHEAD</p> <p>GC TO INTERCEPT POWER ON POLE THAT RUNS TO 2109 AND INSTALL (1) 6 PANEL DISCONNECT</p> <p>SITE ADDRESS: 24401 ½ MULHOLLAND HWY., CALABASAS, CA 91302</p>

Figure 1: Summary of proposed modification (Source: Plans, Page T-1).



TLF notes that the project description states that the fiber terminal will be placed by AT&T. This modification request is for a T-Mobile project. TLF recommends that the City confirm with the Applicant whether identifying AT&T was a mistake or that AT&T has ownership on the same Pole and will provide the fiber terminal.

Figure 2 is photo simulated view of the modification.



**Figure 2:** Simulated view of project (Source: Photo Simulations from December 2020 Submission).

T-Mobile's proposal is depicted in elevation view in Figure 3. TLF notes that there will be no changes at the antenna level.



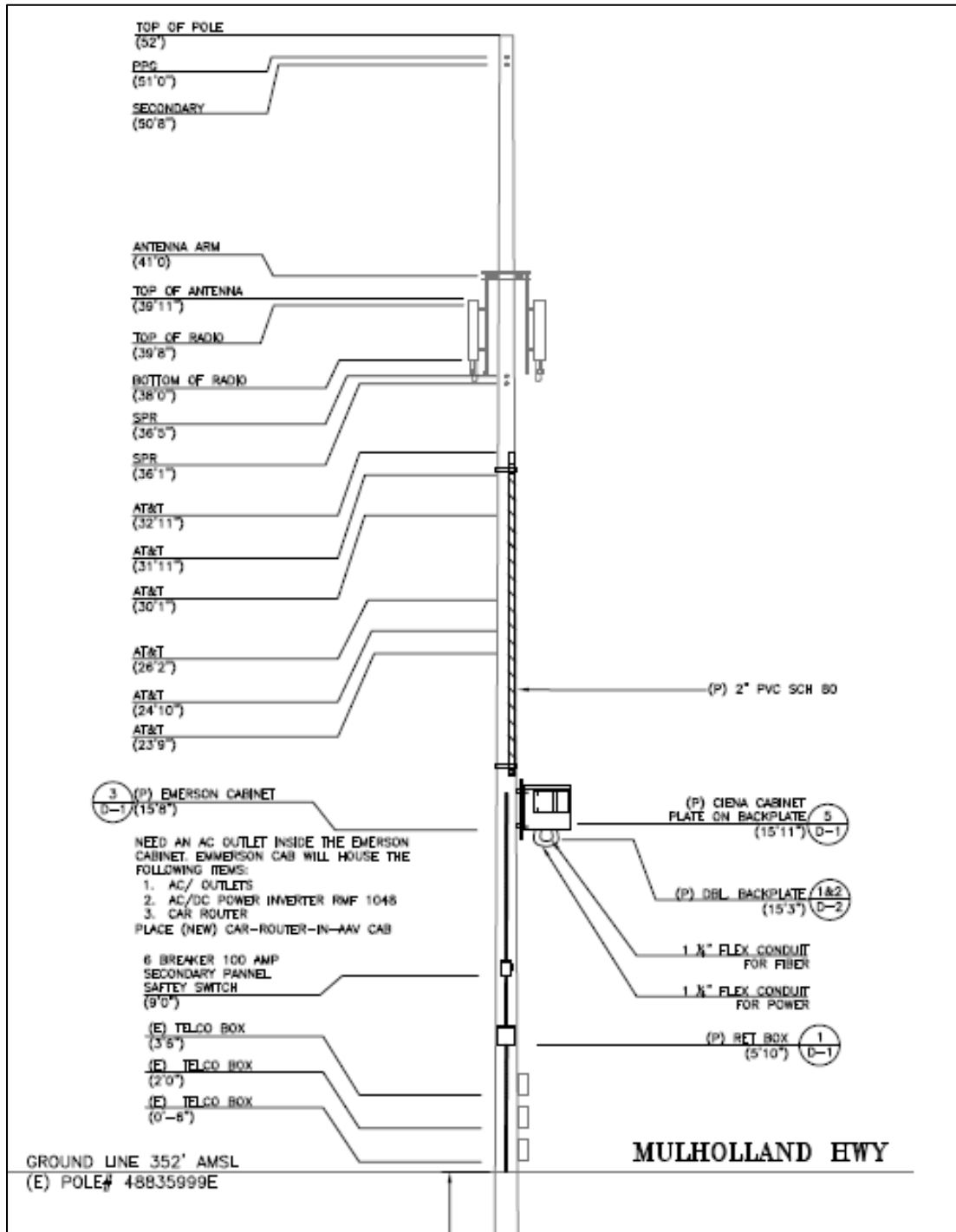

Figure 3: Proposed modification in elevation view (Source: Plans, page A-2, panel 2).

The climbing quadrant can be seen with the proposed Emerson cabinet and Ciena cabinet in Figure 4.

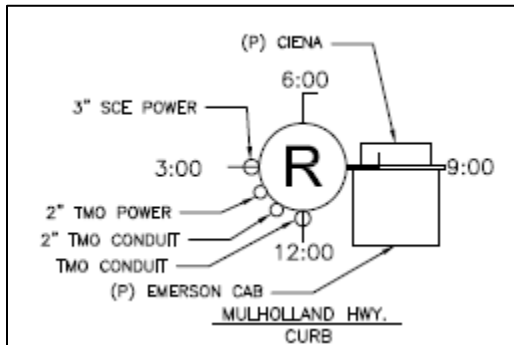

Figure 4: Proposed climbing quadrant (Source: Plans, page A-2, panel 2).

### 3. Section 6409(a) Evaluation

Section 6409(a) requires that a State or local government “may not deny, and shall approve” any “eligible facilities request” for a wireless site collocation or modification so long as it does not cause a “substant[ial] change in [that site’s] physical dimensions.”<sup>2</sup> FCC regulations interpret key terms in this statute and impose certain substantive and procedural limitations on local review.<sup>3</sup> Localities must review applications submitted for approval pursuant to Section 6409(a), but the applicant bears the burden to show it qualifies for mandatory approval.

#### 3.1 Eligible Facilities Request

Section 6409(a)(2) defines an “eligible facilities request” as a request to collocate, remove or replace transmission equipment on an existing wireless tower or base station. FCC regulations define the term “collocation” as “[t]he mounting or installation of transmission equipment on an [existing wireless tower or base station]” and the term “transmission equipment” broadly includes “equipment that facilitates transmission for any [FCC]-licensed or authorized wireless communication service.”<sup>4</sup> A “tower” means any structure built solely or primarily to support transmission equipment, whether it actually supports any equipment or not.<sup>5</sup> In contrast, a “base station” means a non-tower structure in a fixed location approved for use as a wireless support by the local jurisdiction that actually supports transmission equipment at the time a collocation or modification request is submitted.<sup>6</sup>

<sup>2</sup> See 47 U.S.C. § 1455(a).

<sup>3</sup> See *In the Matter of Acceleration of Broadband Deployment by Improving Wireless Facilities Siting Policies, Report and Order*, 29 FCC Rcd. 12865 (Oct. 17, 2014) (codified as 47 C.F.R. §§ 1.40001, *et seq.*) [hereinafter “*Infrastructure Order*”].

<sup>4</sup> See 47 C.F.R. §§ 1.40001(b)(2), (8); see also *Infrastructure Order* at ¶¶ 158–60 (describing examples for transmission equipment) and ¶¶ 178–81 (discussion what constitutes a collocation under Section 6409).

<sup>5</sup> 47 C.F.R. § 1.40001(b)(9); see also *Infrastructure Order* at ¶ 166.

<sup>6</sup> See 47 C.F.R. § 1.40001(b)(1); see also *Infrastructure Order* at ¶ 166. The term “base station” can include DAS and small cells. See 47 C.F.R. § 1.40001(b)(1)(ii).





The FCC also provides that whether a tower or base station “exists” depends on both its *physical* and *legal* status.<sup>7</sup> Section 6409(a) does not mandate approval for collocations and modifications when the support structure was constructed or deployed without proper local review, was not required to undergo local review, or involves equipment that was not properly approved.<sup>8</sup> This rule attempts to preserve the local government’s authority to review wireless facilities in the first instance and withhold statutory benefits under Section 6409(a) in cases where the site operator deployed equipment without all required prior approvals.

In situations where an applicant submits an application for approval pursuant to Section 6409(a) but the local jurisdiction finds that the application does not qualify for mandatory approval, the FCC recommends that the local jurisdiction convert the project into one governed under the traditional standards in the Telecommunications Act.<sup>9</sup>

Here, T-Mobile’s application materials appear to establish that the proposed modification is an eligible facilities request because T-Mobile plans to install and modify its equipment at a physically existing wireless base station.

The installation is a “collocation” on a “base station” because T-Mobile would add its equipment onto a wood utility pole that currently supports wireless equipment but was not originally and solely constructed for wireless use. The proposed equipment within the Emerson cabinet and Ciena cabinet constitute transmission equipment under the FCC’s definitions because T-Mobile deploys each item in order to transmit and receive wireless communications signals to provide its services.

It appears to TLF, that the wireless facility has been built in accordance with its permits. For the purposes of moving to the next steps of our memorandum, we presume that T-Mobile has deployed its current site in accordance with all City permits. The next step is to evaluate whether the proposed modifications will cause a substantial change.

### **3.2 Substantial Change Thresholds for Base Stations**

Section 6409(a) does not mandate approval for all eligible facilities requests. The Applicant must still show that its eligible facilities request will not cause a substantial change.<sup>10</sup>

---

<sup>7</sup> See 47 C.F.R. § 1.40001(b)(5); see also *Infrastructure Order* at ¶ 174.

<sup>8</sup> See *Infrastructure Order* at ¶ 174 (“[I]f a tower or base station was constructed or deployed without proper review, was not required to undergo siting review, or does not support transmission equipment that received another form of affirmative State or local regulatory approval, the governing authority is not obligated to grant a collocation application under Section 6409(a).”).

<sup>9</sup> See *Infrastructure Order* at ¶ 220.

<sup>10</sup> See 47 U.S.C. § 1455(a).



The FCC created a six-part test to determine whether a “substantial change” occurs or not. The test involves thresholds for height increases, width increases, new equipment cabinets, new excavation, changes to concealment elements and permit compliance. A project that exceeds any one threshold causes a substantial change. Additionally, the FCC considers a substantial change to occur when the project replaces the entire support structure or violates a generally applicable law or regulation reasonably related to public health and safety. State and local jurisdictions cannot consider any other criteria or threshold for a substantial change.

### 3.2.1 Height Increases

An increase in height causes a substantial change to a base station when it increases the support structure height 10% or 10 feet (whichever is greater).<sup>11</sup> The height limit is a *cumulative* limit.<sup>12</sup> For almost all base stations, the cumulative limit is measured from the original structure height because the equipment will be horizontally separated.<sup>13</sup>

Here, the proposed modification will not increase the height, thus not triggering a substantial change to this element.

### 3.2.2 Width Increases

An increase in width causes a substantial change to a base station when it adds an appurtenance that protrudes more than six feet from the support structure.<sup>14</sup> This threshold concerns additions *appurtenant* to the support structure, such as new building-mounted equipment that protrudes from the facade.<sup>15</sup>

Unlike height increases, no cumulative limit applies to width increases. Each increase in width must be assessed on its own and without regard to any prior increases in width or new appurtenances from the support structure.

Here, there is no proposed width increase, thus there is no substantial change of this element.

---

<sup>11</sup> See 47 C.F.R. § 1.40001(b)(7)(i).

<sup>12</sup> See *id.* § 1.40001(b)(7)(i)(A); see also *Infrastructure Order* at ¶ 196.

<sup>13</sup> See 47 C.F.R. § 1.40001(b)(7)(i)(A); see also *Infrastructure Order* at ¶ 197.

<sup>14</sup> See 47 C.F.R. § 1.40001(b)(7)(ii); see also *Infrastructure Order* at ¶ 194.

<sup>15</sup> See *Infrastructure Order* at ¶ 194. Although the FCC’s regulations are not explicitly clear on what constitutes an “appurtenance” for this purpose, the *Infrastructure Order* limits its discussion to articles such as cross arms on a utility pole, screen boxes on a building facade or mounts on a tower. See *id.* Accordingly, these criteria most likely do not involve new deployments adjacent to the support structure, such as a new ground-mounted cabinet, even though such deployments may be technically “appurtenant” to the support structure due to interconnection with power and fiber lines. The FCC dealt with these new changes elsewhere in its regulations. See 47 C.F.R. § 1.40001(b)(7)(iv), (b)(6); see also *Infrastructure Order* at ¶ 198–99.



### 3.2.3 Additional Equipment Cabinets

A collocation or modification causes a substantial change when it adds (1) more than the standard number of equipment cabinets for the technology involved (not to exceed four), (2) any new equipment cabinets when no ground-mounted equipment cabinets exist at the current structure or (3) additional ground cabinets more than 10% taller or more voluminous than any current ground cabinets.<sup>16</sup>

Here, T-Mobile's proposal consists of two cabinets. This does not exceed the FCC's equipment cabinet threshold, therefore no substantial change is triggered.

### 3.2.4 New Excavation

A collocation or modification causes a substantial change to a base station when it involves excavation or deployments outside the "site" or "area in proximity to the structure and to other transmission equipment already deployed on the ground."<sup>17</sup> The FCC defines "site" as the leased or owned areas and associated easements for access and utilities but does not define "proximity" for this purpose.<sup>18</sup>

The proposed modification would not include any ground disturbance, thus this specification for substantial change is inapplicable to the instant project.

### 3.2.5 Changes to Concealment Elements

A collocation or modification causes a substantial change when it would "defeat the concealment elements of the support structure."<sup>19</sup> Although the FCC does not provide clear guidance on what change might "defeat" a concealment element, the regulations suggest that the applicant must do at least as much to conceal the new equipment as it did to conceal the originally-approved equipment.<sup>20</sup> Moreover, "the [*Infrastructure*] Order permits States and localities to condition a facility modification request on compliance with concealment measures and generally applicable building and safety codes."<sup>21</sup>

---

<sup>16</sup> See 47 C.F.R. § 1.40001(b)(7)(iii).

<sup>17</sup> See 47 C.F.R. § 1.40001(b)(7)(iv), (b)(6); see also *Infrastructure Order* at ¶ 198–99.

<sup>18</sup> See 47 C.F.R. § 1.40001(b)(6).

<sup>19</sup> See 47 C.F.R. § 1.40001(b)(7)(v).

<sup>20</sup> See *Infrastructure Order* at ¶ 99.

<sup>21</sup> See Brief for Respondent at 20, *Montgomery Cnty. v. FCC*, 811 F.3d 121 (4th Cir. 2015) (No. 15-1240); see also *id.* at 41 (stating that "the Order preserves the authority of States and localities to enforce concealment conditions"). The FCC provided the following example to further elaborate this point: "...[W]here an existing tower is concealed by a tree line and its location below the tree line was a consideration in its approval, an extension that would raise the height of the tower above the tree line would constitute a substantial change, and a zoning authority could impose conditions designed to conceal the modified facility." *Id.* at 41.



Here, T-Mobile will not defeat the existing concealment elements because the proposed equipment will be painted brown to match to the existing Pole.

### 3.2.6 Permit Compliance

Lastly, of the six elements that could cause a request to fall out of Section 6409(a), a collocation or modification causes a substantial change when it would violate a prior condition attached to the original site approval or any modification approval, so long as the condition does not conflict with the thresholds for a substantial change in height, width, excavation or equipment cabinets (but not concealment).<sup>22</sup>

TLF cannot confirm if any unpermitted changes have been made by T-Mobile's wireless site on the Pole. Accordingly, we cannot determine whether a permit condition violation will form an independent basis to find that a substantial change would occur. The City should determine whether any unpermitted changes have taken place by T-Mobile.

### 3.3 Section 6409(a) Conclusion

This project appears to fall within the scope of Section 6409(a) given that T-Mobile's modification does not cause a substantial change.

## 4. Planned Compliance with RF Exposure Regulations

Under the federal Telecommunications Act, the FCC completely occupies the field with respect to RF emissions regulation. The FCC established comprehensive rules for human exposure to RF emissions (the "**FCC Guidelines**").<sup>23</sup> State and local governments cannot regulate wireless facilities based on environmental effects from RF emissions to the extent that the emissions comply with the FCC Guidelines.<sup>24</sup>

Although localities cannot establish their own standards for RF exposure, local officials may require wireless applicants to demonstrate compliance with the FCC Guidelines.<sup>25</sup> Such demonstrations usually involve a predictive calculation because the site has not yet been built.

---

<sup>22</sup> See 47 C.F.R. § 1.40001(b)(7)(vi).

<sup>23</sup> See 47 U.S.C. § 332(c)(7)(B)(iv); see also 47 C.F.R. § 1.1307 *et seq.*; FCC Office of Engineering and Technology, *Evaluating Compliance with FCC Guidelines for Human Exposure to Radiofrequency Electromagnetic Fields*, OET Bulletin 65, ed. 97-01 (1997).

<sup>24</sup> See 47 U.S.C. § 332(c)(7)(B)(iv).

<sup>25</sup> See *In re Procedures for Reviewing Requests for Relief from State and Local Regulations Pursuant to Section 332(c)(7)(B)(iv) of the Communications Act of 1934*, *Report and Order*, 15 FCC Rcd. 22821, 22828–22829 (Nov. 13, 2000) (declining to adopt rules that limit local authority to require compliance demonstrations).



#### 4.1 FCC Guidelines

FCC Guidelines regulate *exposure* rather than *emissions*.<sup>26</sup> Although the FCC establishes a maximum permissible exposure (“MPE”) limit, it does not mandate any specific limitations on power levels applicable to all antennas and requires the antenna operator to adopt exposure-mitigation measures only to the extent that certain persons might become exposed to the emissions. Thus, a relatively low-powered site in proximity to the general population might require more comprehensive mitigation measures than a relatively high-powered site in a remote location accessible only to trained personnel.

The MPE limit also differentiates between “general population” and “occupational” classes. Most people fall into the general population class, which includes anyone who either does not know about potential exposure or knows about the exposure but cannot exert control over the transmitters.<sup>27</sup> The narrower occupational class includes persons exposed through their employment and able to exert control over their exposure.<sup>28</sup> The MPE limit for the general population is five times lower than the MPE limit for the occupational class.

Lastly, the FCC “categorically excludes” certain antennas from routine environmental review when either (1) the antennas create exposures in areas virtually inaccessible to humans or (2) the antennas operate at extreme low power. As a general rule, a wireless site qualified for a categorical exclusion when mounted on a structure built solely or primarily to support FCC-licensed or authorized equipment (*i.e.*, a tower) and such that the lowest point on the lowest transmitter is more than 10 meters (32.8 feet) above ground.<sup>29</sup>

Categorical exclusions establish a presumption that the emissions from the antennas will not significantly impact humans or the human environment. Such antennas are exempt from routine compliance evaluations but not exempt from actual compliance. Under some circumstances, such as a heavily collocated tower or when in close proximity to general population members, even a categorically excluded site will require additional analysis.

#### 4.2 Planned Compliance Evaluation and Recommendations

The FCC does not categorically exclude T-Mobile’s facility from routine compliance review because the underlying structure was constructed utility transmission purposes and not for the primary use for wireless services, and the lowest antenna point is approximately 38’ AGL.

---

<sup>26</sup> See generally Human Exposure to Radio Frequency Fields: Guidelines for Cellular and PCS Sites, *Consumer Guide*, FCC (Oct. 22, 2014), available at <https://www.fcc.gov/guides/human-exposure-rf-fields-guidelines-cellular-and-pcs-sites> (discussing in general terms how wireless sites transmit and how the FCC regulates the emissions).

<sup>27</sup> See 47 C.F.R. § 1.1310, Note 2.

<sup>28</sup> See *id.*

<sup>29</sup> See *id.* § 1.1307(b)(1).



The CMC §17.12.050 requires applicants to submit “[a]n affirmation, under penalty of perjury, that the proposed installation will be FCC compliant, in that it will not cause members of the general public to be exposed to RF levels that exceed the [maximum permissible exposure] levels deemed safe by the FCC.” Any application without such an affirmation is incomplete.

Here, T-Mobile submitted a compliance statement that was submitted under the penalty of perjury. Therefore, the City can consider that the compliance statement as submitted is acceptable.

To promote planned compliance with the FCC Guidelines, the City should now plan on requiring the following conditions of approval for this project:

1. Permittee shall ensure that all federally-required radio frequency signage be installed and maintained at all times in good condition. All such radio frequency signage be constructed of hard materials and be UV stabilized. All radio frequency signage must comply with the sign colors, sign sizes, sign symbols, and sign panel layouts in conformance with the most current versions of ANSI Z535.1, ANSI Z535.2, and ANSI C95.2 standards. All such radio frequency signage, or additional signage immediately adjacent to the radio frequency signage, shall provide a working local or toll-free telephone number to its network operations center that reaches a live person who can exert transmitter power-down control over this site as required by the FCC.
2. In the event that the FCC changes any of radio frequency signage requirements that are applicable to the project site approved herein or ANSI Z535.1, ANSI Z535.2, and ANSI C95.2 standards that are applicable to the project site approved herein are changed, Permittee, within 30 days of each such change, at its own cost and expense, shall replace the signage at the project site to comply with the then current standards.

/JLK



T-Mobile

T-Mobile West LLC  
3257 Guasti Road Ste. 200  
Ontario, CA 91761

PHOTOGRAPHIC VISUALIZATIONS CREATED BY



Synergy a Division of  
Advantage Engineers  
www.synergy.cc

T-Mobile

### SV00872A - LA872 Mulholland Hwy

24401 1/2 Mulholland Hwy  
Calabasas, CA 91302



GEODETIC COORDINATES  
34°07' 0.244" N / 118° 39' 0.580" W

This photo simulation is being provided as a conceptual representation of the proposed wireless facility.  
For exact dimensions and design, please refer to the submitted plans.  
Ascend South West is not Responsible for Post Simulation Production Design Changes, Scaling Error, Omissions, Color Discrepancies, Material Variances or any Construction Related Concern.



Existing Conditions

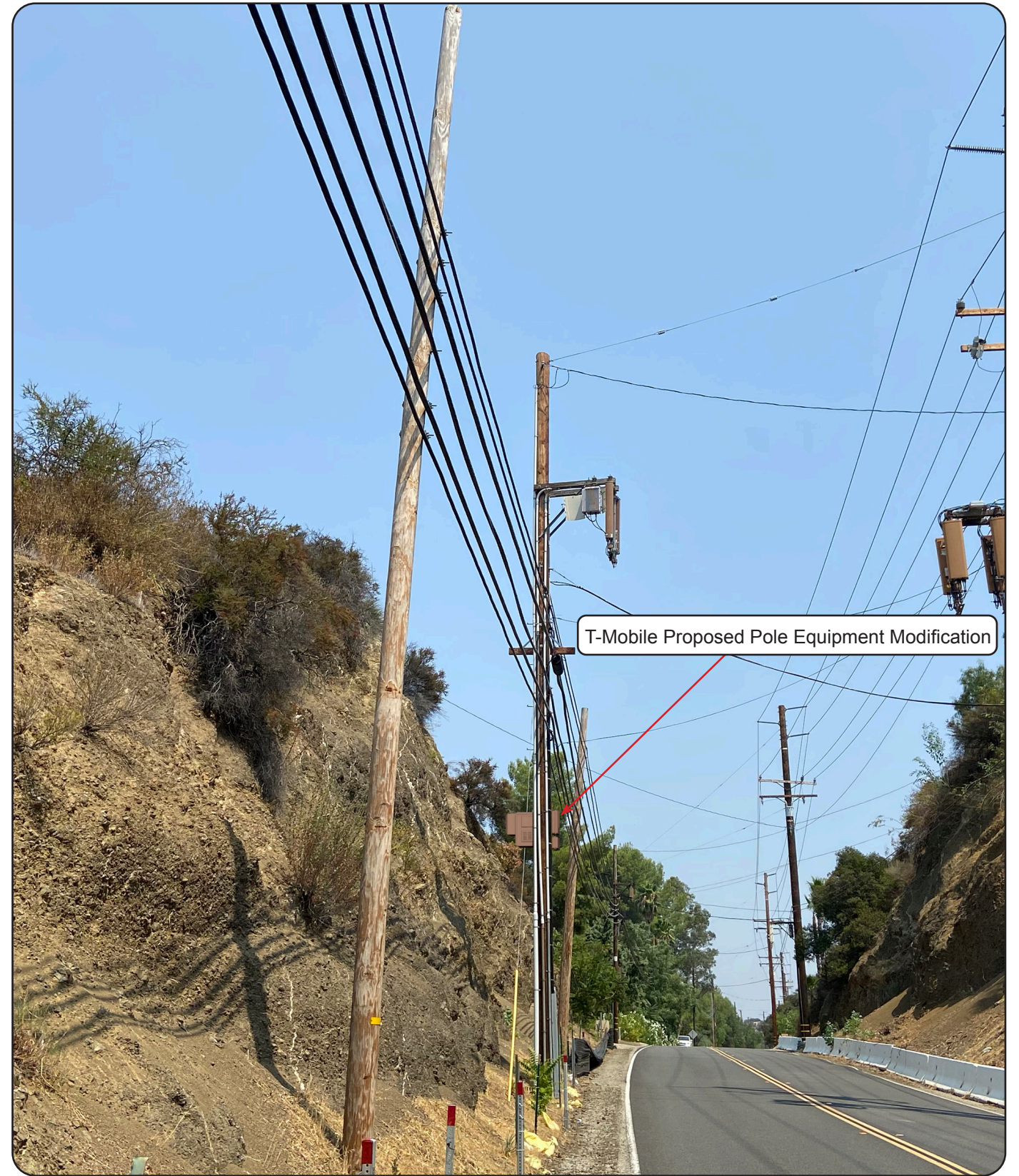

T-Mobile Proposed Pole Equipment Modification

Proposed Site Build

View: 1  
Revision Date: 12/08/20







Existing Conditions



Proposed Site Build

View: 2  
Revision Date: 12/08/20

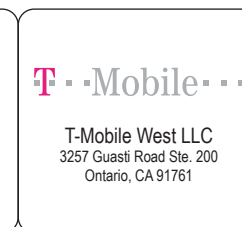



Existing Conditions



Proposed Site Build

View: 3  
Revision Date: 12/08/20

