



CITY of CALABASAS

Community Development Department
Planning Division
100 Civic Center Way
Calabasas, CA 91302
T: 818.224.1600

www.cityofcalabasas.com

January 6, 2021

Synergy – a division of Advantage Engineers LLC
Attn: Lynda McClung
7543 Woodley Ave
Van Nuys, CA 91406

Subject: Notice of Decision for Project No. WTFM-2020-011

Dear Ms. McClung,

At a public hearing on January 6, 2021, the Community Development Director considered testimony given, reviewed the staff report and other documents and materials in the project file, and, based upon the findings presented in the staff report, **APPROVED** your application for the following:

FILE NO.: WTFM-2020-011. A request for a Wireless Telecommunication Facility Minor Modification Permit to modify an existing wireless telecommunication facility in accordance with Section 6409(a) of the 2012 tax relief act. The applicant is proposing the removal and replacement of existing pole-mounted equipment, and modifications within the existing equipment enclosure, at the T-Mobile facility located on a light pole at the athletic field area of Calabasas High School. The subject site is located at 22855 Mulholland Hwy (APN: 2079-021-909), within the Public Facilities (PF) zoning district and Scenic Corridor (-SC) overlay zone.

Your application, described above, is subject to all conditions of approval listed in the attached Exhibit A. Any decision of the Community Development Department may be appealed to the Planning Commission. Appeals must be submitted in writing to the City Clerk (per Chapter 17.74 of the Calabasas Municipal Code) within ten (10) days of the Community Development Director action.

Should you have any questions concerning this application, please contact me at (818) 224-1705 or jrackerby@cityofcalabasas.com.

Sincerely,

Jaclyn Rackerby
Assistant Planner

Attachment: Community Development Director Decision Letter and Report



CITY of CALABASAS

COMMUNITY DEVELOPMENT DIRECTOR DECISION LETTER AND REPORT

FILE NO.: WTFM-2020-011

PROPOSAL: A request for a Wireless Telecommunication Facility Minor Modification Permit to modify an existing wireless telecommunication facility in accordance with Section 6409(a) of the 2012 tax relief act. The applicant is proposing the removal and replacement of existing pole-mounted equipment, and modifications within the existing equipment enclosure, at the T-Mobile facility located on a light pole at the athletic field area of Calabasas High School. The subject site is located at 22855 Mulholland Hwy (APN: 2079-021-909), within the Public Facilities (PF) zoning district and Scenic Corridor (-SC) overlay zone.

APPLICANT: Lynda McClung, Synergy – a division of Advantage Engineers LLC

BACKGROUND:

On November 16, 2020, Synergy – a division of Advantage Engineers filed an application, on behalf of T-Mobile, to upgrade an existing wireless telecommunication facility located at 22855 Mulholland Hwy (APN: 2079-021-909) within the Public Facilities (PF) zoning district and Scenic Corridor (-SC) overlay zone. The application was reviewed by staff and deemed complete on December 8, 2020.

The existing T-Mobile facility was constructed in 2008 (CUP No. 700-013 and OTP No. 007-019), and updated in 2012 (Zoning Clearance Permit, File No. 120001181), for the installation of one new equipment cabinet in compliance with Section 6409(a) of the Middle Class Tax Relief Act.

The proposed project includes the replacement of 3 existing antennas and radome, installation of new RRUs, and the installation of new equipment within the existing equipment room. The project includes replacing the existing radome with a larger one, so there will be a 4'6" increase in height to the facility, as well as an increase in width. This project was reviewed by the Telecom Law Firm for concurrence that the project is an eligible facility request under Section 6409(a) of the Middle Class Tax Relief and Job Creation Act of 2012 (the Act) applies. In a Wireless Telecommunication Memorandum dated December 3, 2020 (Exhibit D), Jonathan Kramer of the Telecom Law Firm stated that the proposed project meets all of the criteria necessary to be eligible for Section 6409(a).

STAFF ANALYSIS:

1. Current Site Condition: The subject site is located at the Calabasas High School, at 22855 Mulholland Hwy within the Public Facilities (PF) zoning district and Scenic Corridor (-SC) overlay zone, and the existing T-mobile facility is comprised of equipment mounted to a light standard near the school's football field, as well as associated ground mounted equipment at the base of the light pole. The existing facility was approved in 2008, and subsequently modified and approved on December 19, 2012. The current facility is made up of three antennas within a radome mounted to the existing light standard, and associated mechanical equipment located within an equipment enclosure at the base of the light pole, screened by an existing 8' tall block wall. Based on photographs provided by the applicant, the site was found to be in good condition (ie. no graffiti, no damage to equipment).
2. Proposed Project: The applicant is requesting permission to upgrade an existing Wireless Telecommunications Facility in accordance with Section 6409(a) of the 2012 Tax Relief Act. The proposal includes the replacement of pole mounted and associated ground mounted equipment at an existing pole-mounted facility at Calabasas High School.
3. Calabasas Municipal Code Requirements: Section 17.12.050 of the CMC regulates the construction, maintenance, and modification of wireless telecommunication facilities within the City of Calabasas. In accordance with Section 17.12.050(B) (4) of the CMC, the ordinance applies to existing facilities which have been previously approved but are now or hereafter modified. Section 17.12.050(F) of the CMC regulates minor modifications of existing facilities that are an eligible facilities request, consistent with Section 6409(A) of the Middle Class Tax Relief and Job Creation Act of 2012. As a result, the applicant has filed for a Minor Modification Permit to perform the requested equipment additions.
4. Section 6409(A) Analysis: On February 17, 2012, Congress passed the "Middle Class Tax Relief and Job Creation Act of 2012" (the "Act"). Section 6409(a) of the Act states that "a State or local government may not deny, and shall approve, any eligible facilities request for a modification of an existing wireless tower or base station that does not substantially change the physical dimensions of such tower or base station." Eligible facilities include requests that involve: (a) collocation of new transmission equipment, (b) removal of transmission equipment; or (c) replacement of transmission equipment. Because the proposed project involves the replacement and installation of existing pole mounted and ground mounted equipment, it qualifies as an eligible facility under the Act. Finally, the proposed project will not substantially change the physical dimensions of the existing tower or base station. As a result, section 6409(a) of the Act applies to the proposed project, and the City shall approve and may not deny this application. Consequently, the project meets all requirements for approval of a Minor Modification Permit and Section 6409(a).

FINDINGS:

Section 17.12.050(F)(5)(b) stipulates that the Director must approve an application for a wireless facility minor modification permit for a collocation or modification to an existing base station on private property only if each of the following findings can be made:

1. *The applicant proposes a collocation or modification to a structure constructed and maintained with all necessary permits in good standing, whether built for the sole or primary purpose of supporting any Federal Communications Commission licensed or authorized antennas and their associated facilities or not, that currently supports existing wireless transmission equipment;*

The proposed project involves the modification of an existing wireless base station located on an existing light standard on the athletic field of Calabasas High School, in the Public Facilities (PF) zoning district and Scenic Corridor (-SC) overlay zone. The site was found to be in good condition (i.e. no graffiti, and no damage to the equipment) and in compliance with all conditions of approval contained within Zoning Clearance Permit File No. 120001181, which is the most recently approved project for this facility. As a result, the proposed project meets this finding.

2. *The proposed collocation or modification does not increase the height of the existing personal wireless telecommunication facility above its lowest height on February 22, 2012, or as approved if constructed after February 22, 2012, by more than ten (10) percent or ten (10) feet, whichever is greater;*

The modifications to the pole mounted equipment involve the replacement of antennas, installation of new RRUs, and replacement of existing radome with a larger radome, which will result in a height increase from 70'1" to 74'7", for a net increase of 4'6". The proposed 4'6" height increase is less than the maximum 10' increase allowable. Therefore, this finding is met.

3. *The proposed collocation or modification does not increase the width of the facility by more than six (6) feet;*

The modifications to the base station involve the replacement of the existing 24" diameter radome with a larger 58" diameter radome. As a result, there will be an increase in the width of the existing facility that is less than the maximum 6' allowable, and this finding is met.

4. *The proposed collocation or modification does not involve the installation of more than the standard number of new equipment cabinets for the technology involved, not to exceed four (4);*

The modifications to the base station include the removal and replacement of antennas and radome, installation of RRUs, and installation of equipment within the existing equipment room. The proposal does not include an increase in the existing number of equipment cabinets, and this finding is met.

5. *The proposed collocation or modification does not involve any excavation outside the lease or license area of the facility, including any access or utility easements;*

The proposed project does not include any new ground disturbance; all proposed changes will be to the existing-pole mounted equipment and within the existing equipment room. Therefore, this finding is met.

6. *The proposed collocation or modification does not defeat any existing concealment elements of the support structure; and*

The antennas at the existing T-Mobile facility are within an existing radome mounted to the light standard, and the ground mounted equipment associated with the facility is within an existing equipment enclosure, and is screened from public view. The proposed modifications will utilize the same concealment elements; antennas and relocated RRUs will be located within the proposed new radome, and the proposed modifications to the associated equipment will be located within the existing equipment enclosure. Additionally, the FRP radome will be painted to match the existing pole. Therefore, the proposed project does not defeat existing concealment elements of the support structure and meets this finding.

7. *The proposed collocation or modification does not violate any prior conditions of approval, except as may be preempted by Section 6409, Title 47, United States Code, section 1455, subdivision (a).*

The existing wireless facility was shown through photos submitted by the applicant to be in good condition (i.e. no graffiti, no damage to existing equipment) and is in compliance with all conditions of approval contained within the original permit and subsequent modifications (Zoning Clearance Permit File No. 120001181 being the most recent). For this reason, the proposed project satisfies this finding.

ENVIRONMENTAL REVIEW:

The City's staff has determined that the project is exempt from environmental review in accordance with Section 21084 of the California Environmental Quality Act (CEQA) and Section 15301 (Existing Facilities) of the CEQA Guidelines.

CONDITIONS OF APPROVAL:

See the attached conditions in Exhibit A.

I have read and agree to the indemnification agreement and attached conditions of approval listed in Exhibit A.

Lynda McClung (Authorized Agent for T-Mobile) 01/06/20
Applicant/Carrier Representative Date

DECISION:

The Director or his/her designee has considered all of the evidence submitted into the administrative record including, but not limited to:

1. All applicable codes and regulations including the City of Calabasas Land Use and Development Code and the City's General Plan;
2. Plans provided by the applicant, as well as any written information; and
3. All related documents, including any necessary environmental documents in order to comply with the California Environmental Quality Act (CEQA), received and/or submitted to the Department.

After considering all of the evidence submitted into the administrative record listed above, I hereby make the following decision:

Approved Denied

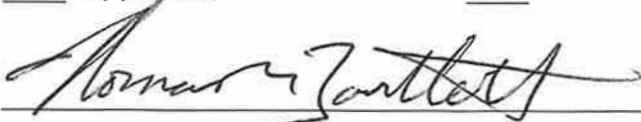

Tom Bartlett, AICP, City Planner

Jan. 6, 2021
Date

ATTACHMENTS:

- Exhibit A: Conditions of Approval
- Exhibit B: Public Hearing Record
- Exhibit C: Project Plans
- Exhibit D: Memo from Telecom Law Firm



CITY of CALABASAS

**COMMUNITY DEVELOPMENT DIRECTOR
DECISION LETTER AND REPORT**

EXHIBIT A: CONDITIONS OF APPROVAL

FILE NO.: WTFM-2020-011

PROPOSAL: A request for a Wireless Telecommunication Facility Minor Modification Permit to modify an existing wireless telecommunication facility in accordance with Section 6409(a) of the 2012 tax relief act. The applicant is proposing the removal and replacement of existing pole-mounted equipment, and modifications within the existing equipment enclosure, at the T-Mobile facility located on a light pole at the athletic field area of Calabasas High School. The subject site is located at 22855 Mulholland Hwy (APN: 2079-021-909), within the Public Facilities (PF) zoning district and Scenic Corridor (-SC) overlay zone.

APPLICANT: Lynda McClung, Synergy – a division of Advantage Engineers LLC

1. The City has determined that City, its employees, agents, and officials should, to the fullest extent permitted by law, be fully protected from any loss, injury, damage, claim, lawsuit, expense, attorney fees, litigation expenses, court costs or any other costs arising out of or in any way related to this File No. WTFM-2020-011 and the issuance of any permit or entitlement in connection therewith, or the activities conducted pursuant to this File No WTFM-2020-011 and the issuance of any permit or entitlement in connection therewith. Accordingly, to the fullest extent permitted by law, Synergy – a division of Advantage Engineers LLC (applicant) and T-Mobile (carrier), and their successors shall defend, indemnify and hold harmless City, its employees, agents and officials, from and against any liability, claims, suits, actions, arbitration proceedings, regulatory proceedings, losses, expenses or costs of any kind, whether actual, alleged or threatened, including, but not limited to, actual attorney fees, litigation expenses and court costs of any kind without restriction or limitation, incurred in relation to, as a consequence of, arising out of or in any way attributable to, actually, allegedly or impliedly, in whole or in part, related to this File No. WTFM-2020-011 and the issuance of any permit or entitlement in connection therewith, or the activities conducted pursuant to this File No. WTFM-2020-011 and the issuance of any permit or entitlement in connection therewith Synergy – a division of Advantage Engineers LLC (applicant) and T-Mobile (carrier), and their successors shall pay such obligations as they are incurred by City, its employees, agents and officials, and in the event of any claim or lawsuit, shall submit a deposit in such amount as the City reasonably determines necessary to protect the City from exposure to fees, costs or liability with respect

to such claim or lawsuit.

2. Compliance with approved plans. The proposed project shall be built in compliance with the approved plans on file with the Planning Division.
3. The project approved herein is depicted on those sets of drawings, elevations, etc., stamped approved by staff on the approval date. Any modifications to these plans must be approved by the Community Development Director prior to the changes on the working drawings or in the field.
4. The subject property shall be developed, maintained, and operated in full compliance with the conditions of this grant and any law, statute, ordinance or other regulation applicable to any development or activity on the subject property. Failure of the applicant or its successors to cease any development or activity not in full compliance shall be a violation of these conditions. Any violation of the conditions of approval may result in the revocation of this approval.
5. This approval shall be valid for one year and eleven days from the date of this decision letter. The permit may be extended in accordance with Section 17.64.050 of the Land Use and Development Code.
6. Prior to commencement of construction, all necessary permits shall be obtained from the Building and Safety Division and Public Works Department.
7. The project is located within a designated A Very High Fire Hazard Severity Zone. The requirements of Chapter 15.04.500 of the Calabasas Municipal Code that references the 2019 California Fire Code as well as the 2019 Consolidated Fire Protection District Code of Los Angeles County, must be incorporated into all plans.
8. The applicant and contractors shall implement all reasonable efforts to reuse and recycle construction and demolition debris, to use environmentally friendly materials, and to provide energy efficient buildings, equipment, and systems. The applicant shall provide proof of recycling quantities to get final clearance of occupancy.
9. Per the Calabasas Municipal Code Chapter 8.16, "no person shall collect and/or dispose of municipal solid waste or recyclable materials in the city without having first been issued a solid waste collection permit. Such permit shall be in addition to any business license or permit otherwise required by the City of Calabasas." Please contact the Public Works Department for a list of permitted haulers. An Encroachment Permit is required prior to placing a refuse bin/container on the street.
10. Construction Activities - Hours of construction activity shall be limited to:

- i. 9:00 a.m. to 2:00 p.m., Monday through Friday
- ii. 8:00 a.m. to 5:00 p.m., Saturday

Stacking of construction worker vehicles, prior to 7:00 a.m. in the morning will be restricted to areas that do not adversely affect adjacent residences or schools. The applicant or its successors shall notify the Public Works Director of the construction employee parking locations, prior to commencement of construction.

11. No new antenna, or additional equipment not included or specified in the stamped approved plans may be installed on the subject site under this permit.
12. No automatic renewal. The grant or approval of a wireless facility minor modification permit shall not renew or extend the underlying permit term.
13. Compliance with previous approvals. The grant or approval of a wireless facility minor modification permit shall be subject to the conditions of approval of the underlying permit, except as may be preempted by Section 6409, subdivision (a).
14. The applicant shall submit to the director an as-built set of plans and photographs depicting the entire personal wireless telecommunications facility as modified, including all transmission equipment and all utilities, within ninety (90) days after the completion of construction.
15. Indemnification. To the fullest extent permitted by law, the applicant and any successors and assigns, shall defend, indemnify and hold harmless City, its employees, agents and officials, from and against any liability, claims, suits, actions, arbitration proceedings, regulatory proceedings, losses, expenses or costs of any kind, whether actual, alleged or threatened, including, but not limited to, actual attorney fees, litigation expenses and court costs of any kind without restriction or limitation, incurred in relation to, as a consequence of, arising out of or in any way attributable to, actually, allegedly or impliedly, in whole or in part, related to the wireless facility minor modification permit and the issuance of any permit or entitlement in connection therewith. The applicant shall pay such obligations as they are incurred by City, its employees, agents and officials, and in the event of any claim or lawsuit, shall submit a deposit in such amount as the City reasonably determines necessary to protect the City from exposure to fees, costs or liability with respect to such claim or lawsuit.
16. The applicant shall comply with all applicable provisions of this Code, any permit issued under this Code, and all other applicable federal, state, and local laws. Any failure by the City to enforce compliance with any applicable laws shall not relieve any applicant of its obligations under this code, any permit issued under this code, or all other applicable laws and regulations.

17. The facility shall be developed, maintained, and operated in full compliance with the conditions of the wireless facility minor modification permit, any other applicable permit, and any law, statute, ordinance or other regulation applicable to any development or activity on the site. Failure of the applicant to cease any development or activity not in full compliance shall be a violation of these conditions. Any violation of this Code, the conditions of approval for the wireless facility minor modification permit, or any other law, statute, ordinance or other regulation applicable to any development or activity on the site may result in the revocation of this permit. The remedies specified in this section shall be cumulative and the city may resort to any other remedy available at law or in equity and resort to any one remedy shall not cause an election precluding the use of any other remedy with respect to a violation.
18. In the event that a court of competent jurisdiction invalidates or limits, in part or in whole, Title 47, United States Code, section 1455, such that such statute would not mandate approval for the collocation or modification granted or deemed granted under a wireless facility minor modification permit, such permit shall automatically expire twelve (12) months from the date of that opinion.
19. The grant, deemed-grant or acceptance of wireless facility minor modification permit shall not waive and shall not be construed or deemed to waive the City's standing in a court of competent jurisdiction to challenge Title 47, United States Code, section 1455 or any wireless facility minor modification permit issued pursuant to Title 47, United States Code, section 1455 or this code.
20. Permittee shall ensure that all federally-required radio frequency signage be installed and maintained at all times in good condition. All such radio frequency signage be constructed of hard materials and be UV stabilized. All radio frequency signage must comply with the sign colors, sign sizes, sign symbols, and sign panel layouts in conformance with the most current versions of ANSI Z535.1, ANSI Z535.2, and ANSI C95.2 standards. All such radio frequency signage, or additional signage immediately adjacent to the radio frequency signage, shall provide a working local or toll-free telephone number to its network operations center that reaches a live person who can exert transmitter power-down control over this site as required by the FCC.
21. In the event that the FCC changes any of radio frequency signage requirements that are applicable to the project site approved herein or ANSI Z535.1, ANSI Z535.2, and ANSI C95.2 standards that are applicable to the project site approved herein are changed, Permittee, within 30 days of each such change, at its own cost and expense, shall replace the signage at the project site to comply with the then current standards.



CITY of CALABASAS

**COMMUNITY DEVELOPMENT DEPARTMENT
DECISION LETTER AND REPORT**

EXHIBIT B: PUBLIC HEARING RECORD

FILE NO.: WTFM-2020-011

PROPOSAL: A request for a Wireless Telecommunication Facility Minor Modification Permit to modify an existing wireless telecommunication facility in accordance with Section 6409(a) of the 2012 tax relief act. The applicant is proposing the removal and replacement of existing pole-mounted equipment, and modifications within the existing equipment enclosure, at the T-Mobile facility located on a light pole at the athletic field area of Calabasas High School. The subject site is located at 22855 Mulholland Hwy (APN: 2079-021-909), within the Public Facilities (PF) zoning district and Scenic Corridor (-SC) overlay zone.

APPLICANT: Lynda McClung, Synergy – a division of Advantage Engineers LLC

1. On Wednesday, January 6, 2021, at 2:00 P.M, City Planner Tom Bartlett held the duly noticed public meeting via Zoom;
2. Jaclyn Rackerby, Assistant Planner presented the staff report for the project, which included the staff recommendation to approve the project. Following the staff report the designee of the Director, City Planner Tom Bartlett, opened the public hearing;
3. The applicant spoke in favor of the project.
4. With there being no other persons to present testimony regarding the application, the public hearing was closed.
5. The City Planner announced the decision as Approved.

WIRELESS PLANNING MEMORANDUM

TO: Ms. Jaclyn Rackerby
FROM: Dr. Jonathan Kramer *Jonathan Kramer*
DATE: December 3, 2020
RE: (WTFM-2020-011) Technical Review for Proposed Modifications to a Wireless Site Mounted on a Stadium Light Pole located near 22855 Mulholland Hwy Submitted for Approval Under 47 U.S.C. § 1455(a)

Applicant: Synergy on behalf of T-Mobile
Site Name: Calabasas High Field LP

1. Summary

The City of Calabasas (the “**City**”) requested that Telecom Law Firm, PC (“**TLF**”) review the Synergy, a division of Advantage Engineers, LLC (“the **Applicant**”) application submitted on behalf of T-Mobile West LLC (“**T-Mobile**”) to modify its existing wireless site located on a stadium light standard (“**Pole**”) located near 22855 Mulholland Hwy.

It appears that the current modification proposal will qualify for Section 6409(a), this is because T-Mobile proposed a modification that does not cause a substantial change. Accordingly, this project is subject to a 60-day shot clock.

T-Mobile’s proposed modification will demonstrate planned compliance with the FCC’s RF emission guidelines if the necessary RF signage and notifications are posted and maintained. Any redesign of this project that changes the antennas, locations, or emissions will necessitate a re-review of the planned emissions.

This memorandum reviews the application and related materials for technical and regulatory issues specific to wireless infrastructure. Although many technical issues implicate legal issues, the analysis and recommendations contained in this memorandum do not constitute legal advice.

2. Project Background and Description

On February 20, 2008, the Planning Commission issued an approval for a conditional use permit (“**CUP**”) 700-013 to install three cabinets within a block wall enclosure and three antennas mounted to be mounted to an existing stadium light pole. Only two of the three cabinets were constructed through this CUP.

On December 18, 2012, the Department of Community Development issued an approval to install one cabinet with the existing approved lease area with no antenna changes.

On November 16, 2020, the Applicant submitted application materials that show T-Mobile is seeking approval to modify its existing wireless site pursuant to Section 6409(a) of the Middle Class Tax Relief and Job Creation Act of 2012.¹ Accordingly, this memorandum focuses its review to the initial questions: (1) whether Section 6409(a) applies to this proposal, and (2) whether the project demonstrates planned compliance with the FCC's radio frequency exposure guidelines.

The submitted project plans dated August 7, 2020 ("**Plans**") show that T-Mobile currently operates a wireless facility comprising of three panel antennas within a 24" fiber reinforced plastic ("FRP") radome mounted on top of the Pole. Additionally, within the FRP radome, T-Mobile operates tower mounted amplifiers ("**TMA**s"). The remaining associated equipment is housed within an 8' tall walled equipment enclosure. See Figure 1 for an overview of T-Mobile's wireless facility.



Figure 1: Overview of the existing wireless facility (Source: Applicant submitted Photo Simulations).

T-Mobile is now proposing to remove and replace three of its existing antennas and add three new remote radio units ("**RRUs**") within a new larger sized FRP ventilated radome on the Pole.

¹ See Section 6409(a) of the Middle-Class Tax Relief and Job Creation Act of 2012, Pub. L. No. 112-96, 126 Stat. 156. (Feb. 22, 2012) (codified as 47 U.S.C. § 1455(a)).



A summary of the proposed modification is shown in Figure 2.

PROJECT DESCRIPTION	
THE PROJECT ENTAILS: T-MOBILE PROPOSED TO MODIFY (E) WIRELESS TELECOMMUNICATIONS SITE BY: L600/670048:	
1. REMOVE AND REPLACE EXISTING RADOME WITH NEW RADOME WITH VENTILATION TO ACCOMMODATE NEW ANTENNAS AND RADIOS AND EXISTING TMAS	
2. REPLACE (3) TMBXX WITH (3) FFHH -65A-R3 4FT (1) PER SECTOR	
3. ADD (3) RRU 4449S NEAR ANTENNAS, (1) PER SECTOR	
4. ADD (1) 6X12 HCS 40M 6AWG	
5. REMOVE AWS/PCS DIPLEXERS	
6. INSTALL NEW FRP RADOME	
EQUIPMENT:	
1. REPLACE DUS41S WITH (2) BB6630S BELOW POWER RACK, (1 FOR LTE, 1 FOR N600)	
2. INSTALL SECONDARY POWER RACK	
3. REMOVE LMU	
4. REPLACE 4 PSU01 WITH 6 PSU03	
5. ADD (1) PDU04	
CM NOTES:	
1. POWER UPGRADE NEEDED (DC POWER)	
2. UPDATE A/C BREAKER TO 150 AMPS AND WIRING AS REQUIRED	
3. PAINT TO MATCH NEW RADOME	

Figure 2: Summary of proposed modification (Source: Plans, Page T-1).

T-Mobile’s proposed modifications on the Pole are depicted in elevation view in Figure 3.

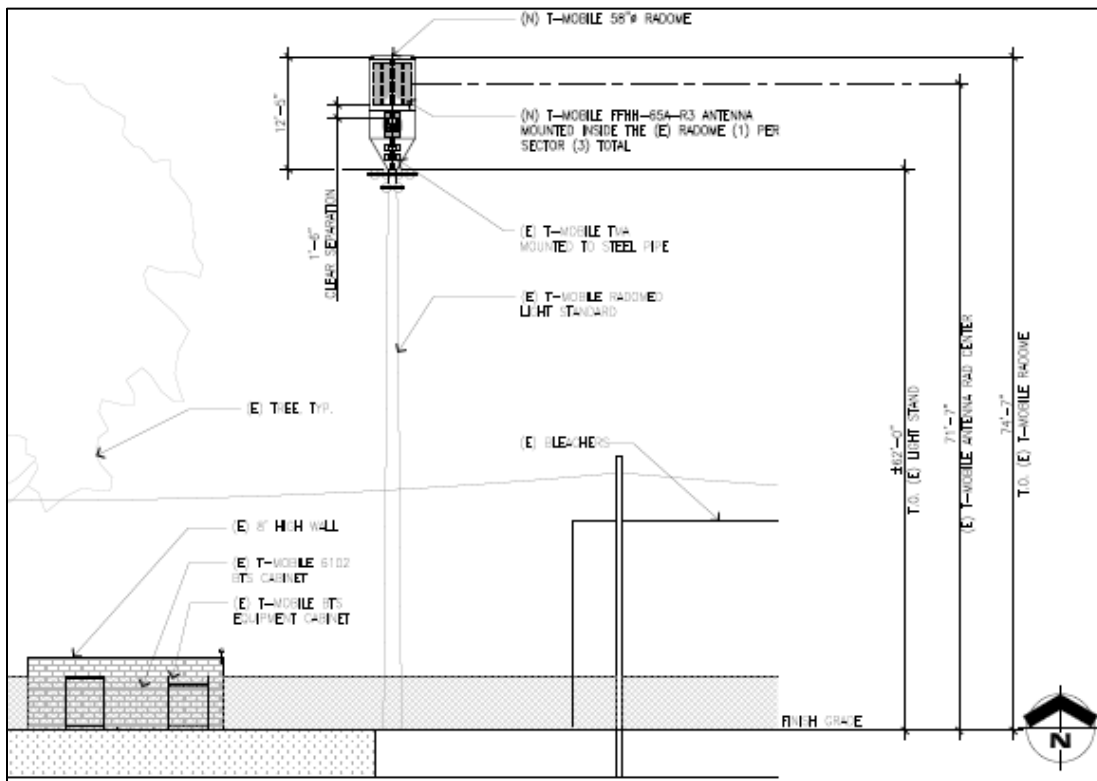

Figure 3: Elevation view of T-Mobile’s proposed wireless site. (Source: Plans, page A-3, panel 2).

TLF notes the Pole with the proposed FRP radome will result in the height of wireless facility increasing from the existing height of 70'1" above ground level (“AGL”) to 74'7" AGL.



Figure 4 shows the existing antenna layout plan and Figure 5 shows the proposed antenna layout plan.

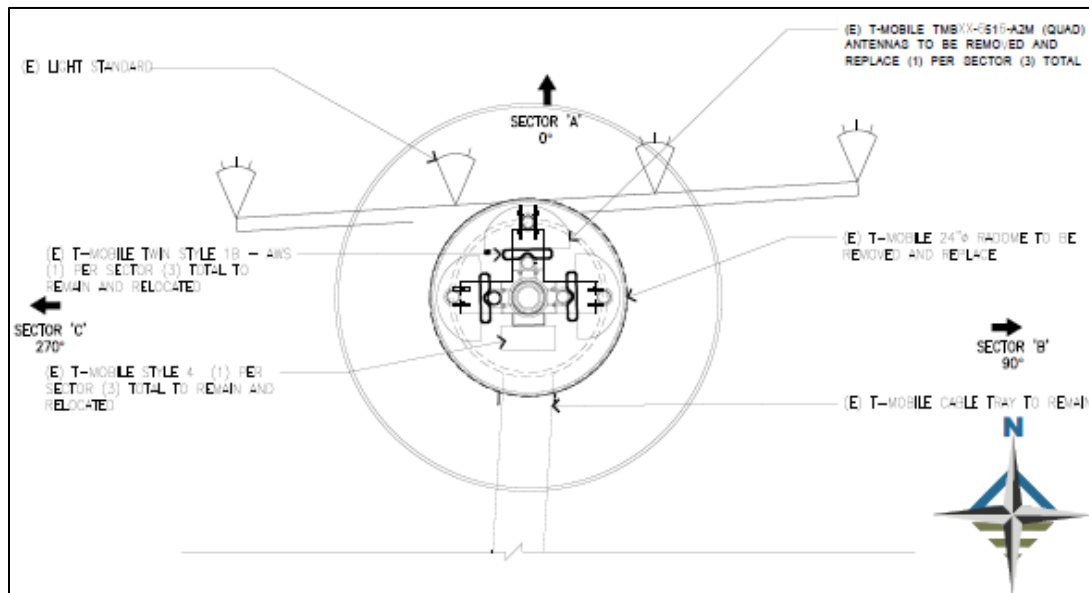

Figure 4: Existing antenna layout plan (Source: Plans, page A-2, panel 2).

The existing 24" FRP radome will be replaced with a new ventilated FRP radome with an increased size of 58".

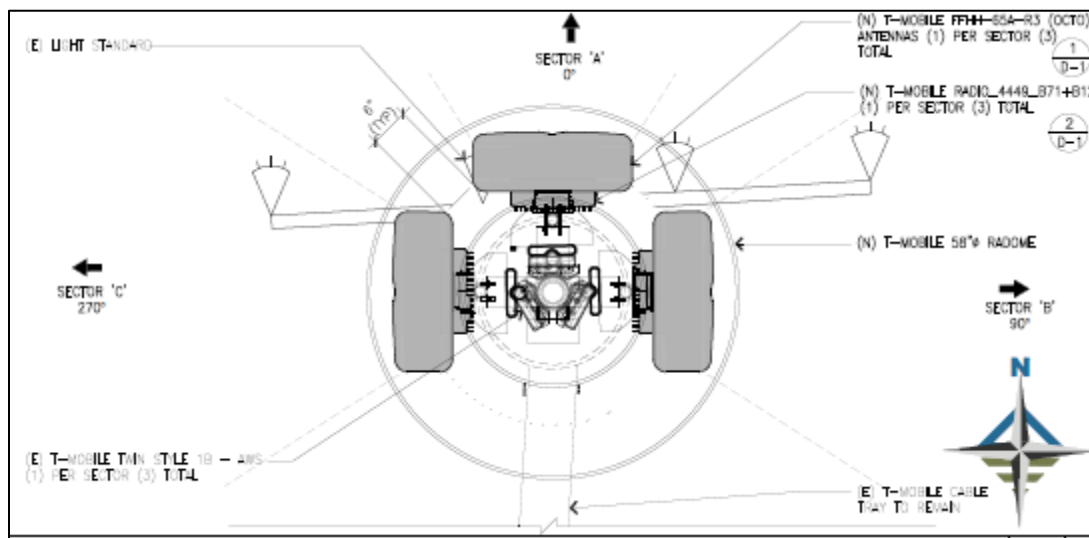

Figure 5: Proposed antenna layout plan (Source: Plans, page A-2, panel 3).

Sector A has one panel antenna oriented toward 0° true north (“TN”), Sector B has one panel antenna oriented at 90° TN and Sector C has one panel antenna oriented at 270° TN. The sector orientations will remain unchanged after the modification.



Figure 6 shows an expanded view of the proposed radome.

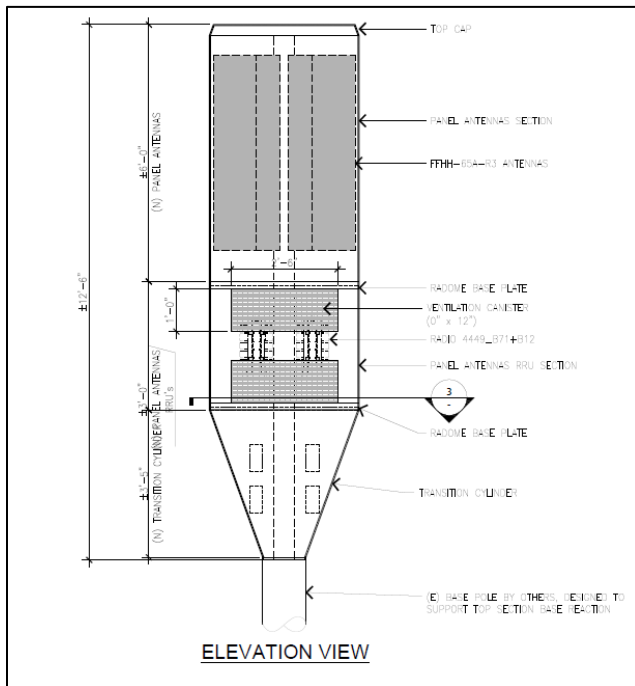

Figure 6: Simulated view of T-Mobile’s proposal (Source: Plans, page D-2, panel 1).

T-Mobile has proposed modifications within its equipment room. These modifications are shown in detail in Figure 7.

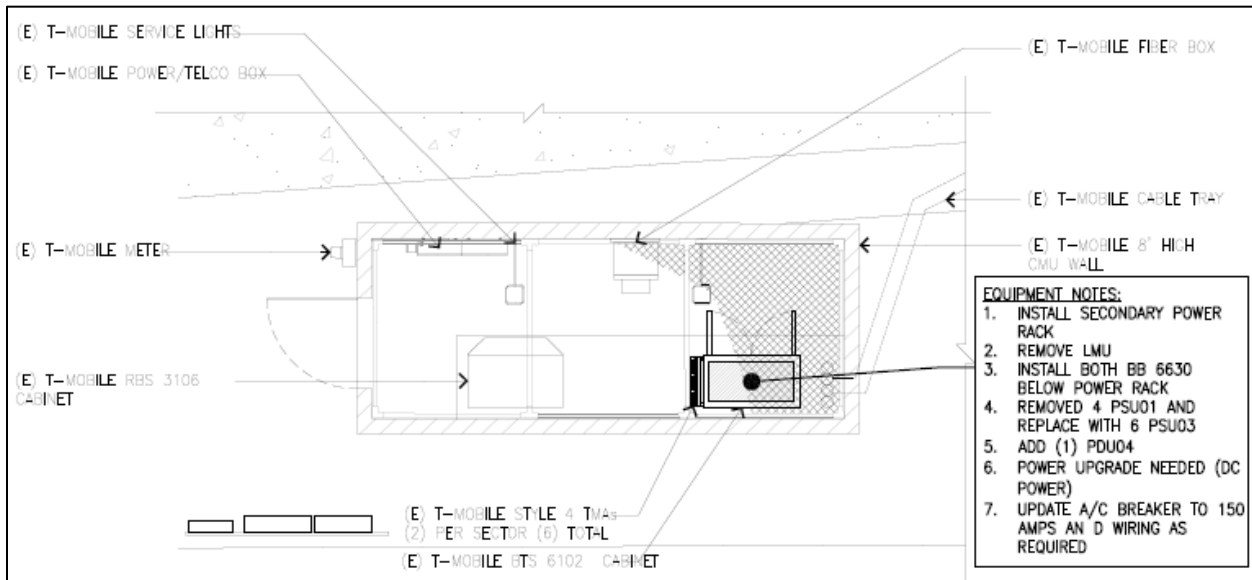

Figure 7: Proposed modifications in Verizon’s equipment room (Source: Plans, page A-2, panel 3).

Figure 8 shows a photo simulation of T-Mobile’s proposal.





Figure 8: Simulated view of T-Mobile’s proposal (Source: Applicant submitted Photo Simulations).

3. Section 6409(a) Evaluation

Section 6409(a) requires that a State or local government “may not deny, and shall approve” any “eligible facilities request” for a wireless site collocation or modification so long as it does not cause a “substant[ial] change in [that site’s] physical dimensions.”² FCC regulations interpret key terms in this statute and impose certain substantive and procedural limitations on

² See 47 U.S.C. § 1455(a).



local review.³ Localities must review applications submitted for approval pursuant to Section 6409(a), but the applicant bears the burden to show it qualifies for mandatory approval.

3.1 Eligible Facilities Request

Section 6409(a)(2) defines an “eligible facilities request” as a request to collocate, remove or replace transmission equipment on an existing wireless tower or base station. FCC regulations define the term “collocation” as “[t]he mounting or installation of transmission equipment on an [existing wireless tower or base station]” and the term “transmission equipment” broadly includes “equipment that facilitates transmission for any [FCC]-licensed or authorized wireless communication service.”⁴ A “tower” means any structure built solely or primarily to support transmission equipment, whether it actually supports any equipment or not.⁵ In contrast, a “base station” means a non-tower structure in a fixed location approved for use as a wireless support by the local jurisdiction that actually supports transmission equipment at the time a collocation or modification request is submitted.⁶

The FCC also provides that whether a tower or base station “exists” depends on both its *physical* and *legal* status.⁷ Section 6409(a) does not mandate approval for collocations and modifications when the support structure was constructed or deployed without proper local review, was not required to undergo local review, or involves equipment that was not properly approved.⁸ This rule attempts to preserve the local government’s authority to review wireless facilities in the first instance and withhold statutory benefits under Section 6409(a) in cases where the site operator deployed equipment without all required prior approvals.

In situations where an applicant submits an application for approval pursuant to Section 6409(a) but the local jurisdiction finds that the application does not qualify for mandatory approval, the FCC recommends that the local jurisdiction convert the project into one governed under the traditional standards in the Telecommunications Act.⁹

³ See *In the Matter of Acceleration of Broadband Deployment by Improving Wireless Facilities Siting Policies, Report and Order*, 29 FCC Rcd. 12865 (Oct. 17, 2014) (codified as 47 C.F.R. §§ 1.40001, *et seq.*) [hereinafter “*Infrastructure Order*”].

⁴ See 47 C.F.R. §§ 1.40001(b)(2), (8); see also *Infrastructure Order* at ¶¶ 158–60 (describing examples for transmission equipment) and ¶¶ 178–81 (discussion what constitutes a collocation under Section 6409).

⁵ 47 C.F.R. § 1.40001(b)(9); see also *Infrastructure Order* at ¶ 166.

⁶ See 47 C.F.R. § 1.40001(b)(1); see also *Infrastructure Order* at ¶ 166. The term “base station” can include DAS and small cells. See 47 C.F.R. § 1.40001(b)(1)(ii).

⁷ See 47 C.F.R. § 1.40001(b)(5); see also *Infrastructure Order* at ¶ 174.

⁸ See *Infrastructure Order* at ¶ 174 (“[I]f a tower or base station was constructed or deployed without proper review, was not required to undergo siting review, or does not support transmission equipment that received another form of affirmative State or local regulatory approval, the governing authority is not obligated to grant a collocation application under Section 6409(a).”).

⁹ See *Infrastructure Order* at ¶ 220.



Here, T-Mobile's application materials appear to establish that the proposed modification is an eligible facilities request because T-Mobile plans to install its equipment at a physically existing wireless base station.

The installation is a "collocation" on a "base station" because T-Mobile would add its equipment on a stadium light that currently supports wireless equipment but was not originally and solely constructed for wireless use. The antennas and the RRUs constitute transmission equipment under the FCC's definitions because T-Mobile deploys each item to transmit and receive wireless communications signals to provide its services. It appears to TLF that T-Mobile's current site is in compliance with the City-issued permits therefore, the current site has a legal existence

The next step is to evaluate whether the proposed modifications will cause a substantial change.

3.2 Substantial Change Thresholds for Base Stations

Section 6409(a) does not mandate approval for all eligible facilities requests. The Applicant must still show that its eligible facilities request will not cause a substantial change.¹⁰

The FCC created a six-part test to determine whether a "substantial change" occurs or not. The test involves thresholds for height increases, width increases, new equipment cabinets, new excavation, changes to concealment elements and permit compliance. A project that exceeds any one threshold causes a substantial change. Additionally, the FCC considers a substantial change to occur when the project replaces the entire support structure or violates a generally applicable law or regulation reasonably related to public health and safety. State and local jurisdictions cannot consider any other criteria or threshold for a substantial change.

3.2.1 Height Increases

An increase in height causes a substantial change to a base station when it increases the support structure height 10% or 10 feet (whichever is greater).¹¹ The height limit is a *cumulative* limit.¹² For almost all base stations, the cumulative limit is measured from the original structure height because the equipment will be horizontally separated.¹³

Here, even though the proposed modification will cause an increase in the height of the Pole this increase in height will not trigger a substantial change.

¹⁰ See 47 U.S.C. § 1455(a).

¹¹ See 47 C.F.R. § 1.40001(b)(7)(i).

¹² See *id.* § 1.40001(b)(7)(i)(A); see also *Infrastructure Order* at ¶ 196.

¹³ See 47 C.F.R. § 1.40001(b)(7)(i)(A); see also *Infrastructure Order* at ¶ 197.



3.2.2 Width Increases

An increase in width causes a substantial change to a base station when it adds an appurtenance that protrudes more than six feet from the support structure.¹⁴ This threshold concerns additions *appurtenant* to the support structure, such as new building-mounted equipment that protrudes from the facade.¹⁵

Unlike height increases, no cumulative limit applies to width increases. Each increase in width must be assessed on its own and without regard to any prior increases in width or new appurtenances from the support structure.

Here, the proposed width of the Pole will increase but this increase in width will not cause a substantial change.

3.2.3 Additional Equipment Cabinets

A collocation or modification causes a substantial change when it adds (1) more than the standard number of equipment cabinets for the technology involved (not to exceed four), (2) any new equipment cabinets when no ground-mounted equipment cabinets exist at the current structure or (3) additional ground cabinets more than 10% taller or more voluminous than any current ground cabinets.¹⁶

Here, T-Mobile's proposal does not include an increase in the number of equipment cabinets that will cause a substantial change.

3.2.4 New Excavation

A collocation or modification causes a substantial change to a base station when it involves excavation or deployments outside the "site" or "area in proximity to the structure and to other transmission equipment already deployed on the ground."¹⁷ The FCC defines "site" as the

¹⁴ See 47 C.F.R. § 1.40001(b)(7)(ii); see also *Infrastructure Order* at ¶ 194.

¹⁵ See *Infrastructure Order* at ¶ 194. Although the FCC's regulations are not explicitly clear on what constitutes an "appurtenance" for this purpose, the *Infrastructure Order* limits its discussion to articles such as cross arms on a utility pole, screen boxes on a building facade or mounts on a tower. See *id.* Accordingly, these criteria most likely do not involve new deployments adjacent to the support structure, such as a new ground-mounted cabinet, even though such deployments may be technically "appurtenant" to the support structure due to interconnection with power and fiber lines. The FCC dealt with these new changes elsewhere in its regulations. See 47 C.F.R. § 1.40001(b)(7)(iv), (b)(6); see also *Infrastructure Order* at ¶ 198–99.

¹⁶ See 47 C.F.R. § 1.40001(b)(7)(iii).

¹⁷ See 47 C.F.R. § 1.40001(b)(7)(iv), (b)(6); see also *Infrastructure Order* at ¶ 198–99.



leased or owned areas and associated easements for access and utilities, but does not define “proximity” for this purpose.¹⁸

Here, the proposed modification would not cause any ground disturbance, thus this specification for substantial change is inapplicable to the instant project.

3.2.5 Changes to Concealment Elements

A collocation or modification causes a substantial change when it would “defeat the concealment elements of the support structure.”¹⁹ Although the FCC does not provide clear guidance on what change might “defeat” a concealment element, the regulations suggest that the applicant must do at least as much to conceal the new equipment as it did to conceal the originally-approved equipment.²⁰ Moreover, “the [*Infrastructure*] Order permits States and localities to condition a facility modification request on compliance with concealment measures and generally applicable building and safety codes.”²¹

Here, the proposed modification would not defeat the concealment elements because the antennas and associated equipment will remain screened within the new FRP radome painted to match the Pole or will be situated within the existing equipment enclosure.

3.2.6 Permit Compliance

Lastly, of the six elements that could cause a request to fall out of Section 6409(a), a collocation or modification causes a substantial change when it would violate a prior condition attached to the original site approval or any modification approval, so long as the condition does not conflict with the thresholds for a substantial change in height, width, excavation or equipment cabinets (but not concealment).²²

It does not appear to TLF that there are any unpermitted changes to the Pole. Accordingly, this section will not form an independent basis to find that a substantial change will occur.

¹⁸ See 47 C.F.R. § 1.40001(b)(6).

¹⁹ See 47 C.F.R. § 1.40001(b)(7)(v).

²⁰ See *Infrastructure Order* at ¶ 99.

²¹ See Brief for Respondent at 20, *Montgomery Cnty. v. FCC*, 811 F.3d 121 (4th Cir. 2015) (No. 15-1240); see also *id.* at 41 (stating that “the Order preserves the authority of States and localities to enforce concealment conditions”). The FCC provided the following example to further elaborate this point: “[W]here an existing tower is concealed by a tree line and its location below the tree line was a consideration in its approval, an extension that would raise the height of the tower above the tree line would constitute a substantial change, and a zoning authority could impose conditions designed to conceal the modified facility.” *Id.* at 41.

²² See 47 C.F.R. § 1.40001(b)(7)(vi).



3.3 Section 6409(a) Conclusion

This project, as proposed, appears to qualify for Section 6409(a) treatment and should be subject to a 60-day shot clock.

4. Planned Compliance with RF Exposure Regulations

Under the federal Telecommunications Act, the FCC completely occupies the field with respect to RF emissions regulation. The FCC established comprehensive rules for human exposure to RF emissions (the “**FCC Guidelines**”).²³ State and local governments cannot regulate wireless facilities based on environmental effects from RF emissions to the extent that the emissions comply with the FCC Guidelines.²⁴

Although localities cannot establish their own standards for RF exposure, local officials may require wireless applicants to demonstrate compliance with the FCC Guidelines.²⁵ Such demonstrations usually involve a predictive calculation because the site has not yet been built.

4.1 FCC Guidelines

FCC Guidelines regulate *exposure* rather than *emissions*.²⁶ Although the FCC establishes a maximum permissible exposure (“**MPE**”) limit, it does not mandate any specific limitations on power levels applicable to all antennas and requires the antenna operator to adopt exposure-mitigation measures only to the extent that certain persons might become exposed to the emissions. Thus, a relatively low-powered site in proximity to the general population might require more comprehensive mitigation measures than a relatively high-powered site in a remote location accessible only to trained personnel.

The MPE limit also differentiates between “general population” and “occupational” classes. Most people fall into the general population class, which includes anyone who either does not know about potential exposure or knows about the exposure but cannot exert control over the transmitters.²⁷ The narrower occupational class includes persons exposed through their

²³ See 47 U.S.C. § 332(c)(7)(B)(iv); see also 47 C.F.R. § 1.1307 *et seq.*; FCC Office of Engineering and Technology, *Evaluating Compliance with FCC Guidelines for Human Exposure to Radiofrequency Electromagnetic Fields*, OET Bulletin 65, ed. 97-01 (1997).

²⁴ See 47 U.S.C. § 332(c)(7)(B)(iv).

²⁵ See *In re Procedures for Reviewing Requests for Relief from State and Local Regulations Pursuant to Section 332(c)(7)(B)(iv) of the Communications Act of 1934*, *Report and Order*, 15 FCC Rcd. 22821, 22828–22829 (Nov. 13, 2000) (declining to adopt rules that limit local authority to require compliance demonstrations).

²⁶ See generally Human Exposure to Radio Frequency Fields: Guidelines for Cellular and PCS Sites, *Consumer Guide*, FCC (Oct. 22, 2014), available at <https://www.fcc.gov/guides/human-exposure-rf-fields-guidelines-cellular-and-pcs-sites> (discussing in general terms how wireless sites transmit and how the FCC regulates the emissions).

²⁷ See 47 C.F.R. § 1.1310, Note 2.



employment and able to exert control over their exposure.²⁸ The MPE limit for the general population is five times lower than the MPE limit for the occupational class.

Lastly, the FCC “categorically excludes” certain antennas from routine environmental review when either (1) the antennas create exposures in areas virtually inaccessible to humans or (2) the antennas operate at extreme low power. As a general rule, a wireless site qualified for a categorical exclusion when mounted on a structure built solely or primarily to support FCC-licensed or authorized equipment (*i.e.*, a tower) and such that the lowest point on the lowest transmitter is more than 10 meters (32.8 feet) above ground.²⁹

Categorical exclusions establish a presumption that the emissions from the antennas will not significantly impact humans or the human environment. Such antennas are exempt from routine compliance evaluations but not exempt from actual compliance. Under some circumstances, such as a heavily collocated tower or when in close proximity to general population members, even a categorically excluded site will require additional analysis.

4.2 Planned Compliance Evaluation and Recommendations

The FCC does not categorically exclude T-Mobile’s facility from routine compliance review because the underlying structure was constructed for illumination purposes for the stadium and not for the primary use for wireless services.

The Calabasas Municipal Code (“CMC”) §17.12.050(C)(2)(f) requires applicants to submit “[a]n affirmation, under penalty of perjury, that the proposed installation will be FCC compliant, in that it will not cause members of the general public to be exposed to RF levels that exceed the [maximum permissible exposure] levels deemed safe by the FCC.” Any application without such an affirmation is incomplete. Here, T-Mobile submitted a signed compliance letter prepared by EBI Consulting and dated August 3, 2020. The compliance letter certifies compliance under penalty of perjury as required under the Code. Accordingly, this application meets the City’s standard.

To promote planned compliance with the FCC Guidelines, the City should now plan on requiring the following conditions of approval for this project:

1. Permittee shall ensure that all federally-required radio frequency signage be installed and maintained at all times in good condition. All such radio frequency signage be constructed of hard materials and be UV stabilized. All radio frequency signage must comply with the sign colors, sign sizes, sign symbols, and sign panel layouts in conformance with the most current versions of ANSI Z535.1, ANSI Z535.2, and ANSI

²⁸ See *id.*

²⁹ See *id.* § 1.1307(b)(1).



C95.2 standards. All such radio frequency signage, or additional signage immediately adjacent to the radio frequency signage, shall provide a working local or toll-free telephone number to its network operations center that reaches a live person who can exert transmitter power-down control over this site as required by the FCC.

2. In the event that the FCC changes any of radio frequency signage requirements that are applicable to the project site approved herein or ANSI Z535.1, ANSI Z535.2, and ANSI C95.2 standards that are applicable to the project site approved herein are changed, Permittee, within 30 days of each such change, at its own cost and expense, shall replace the signage at the project site to comply with the then current standards.

/JLK

/JLK



T-Mobile

4100 Guardian St., Suite 101
Simi Valley, CA 93063

T-Mobile

SV11190C Calabasas High Field LP

22855 Mulholland Highway
Calabasas, CA 91302

PHOTOGRAPHIC VISUALIZATIONS CREATED BY

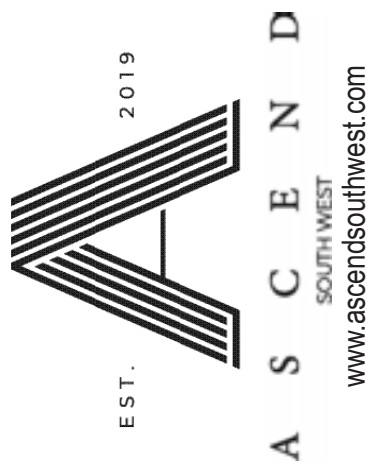

Synergy a Division of
Advantage Engineers
www.synergy.cc

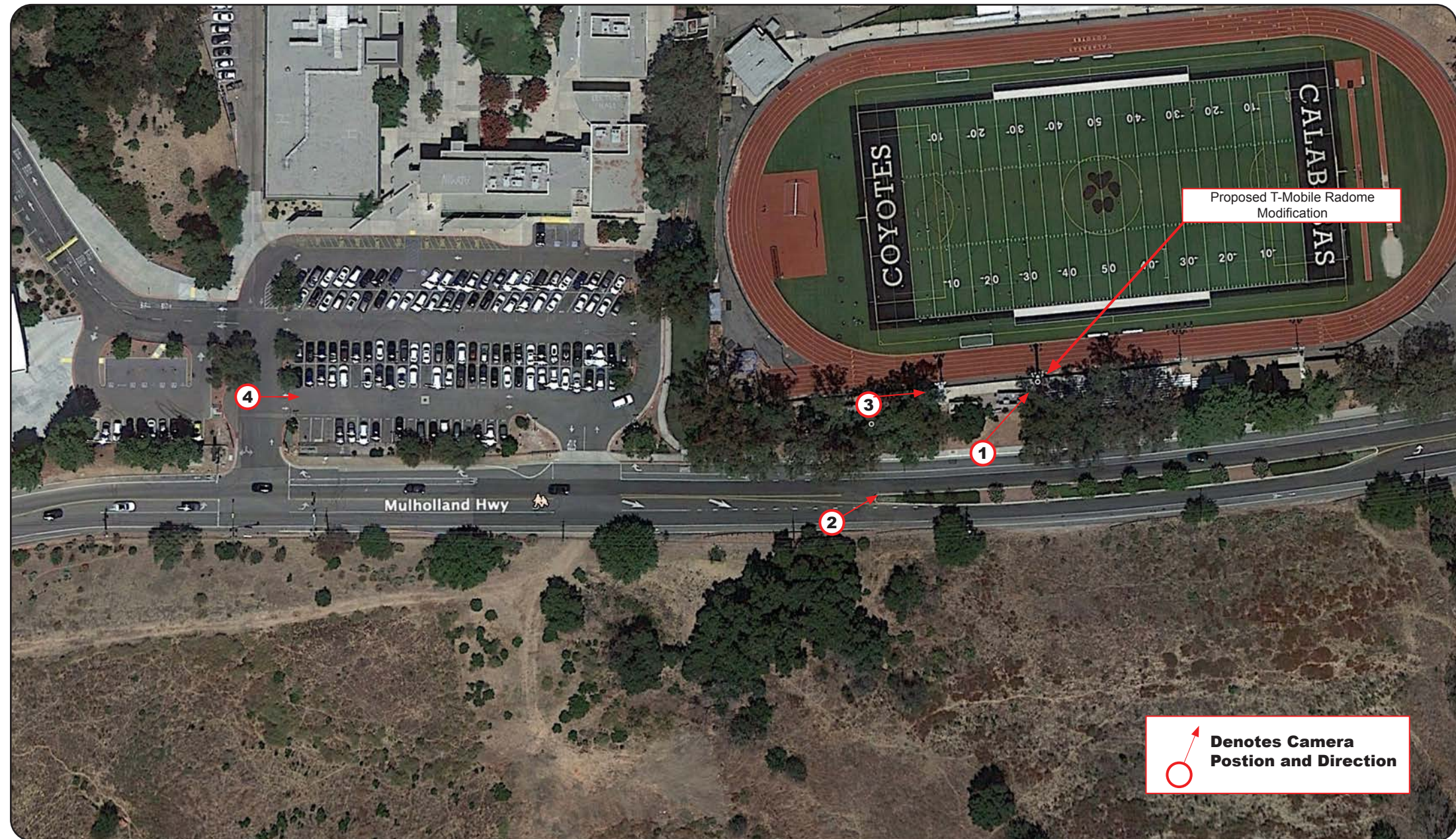

Denotes Camera
Position and Direction

GEODETIC COORDINATES
34° 8'16.17"N / 118°37'34.82"W

approximate

This photo simulation is being provided as a conceptual representation of the proposed wireless facility.
For exact dimensions and design, please refer to the submitted plans.
Ascend South West is not Responsible for Post Simulation Production Design Changes, Scaling Error, Omissions, Color Discrepancies, Material Variances or
any Construction Related Concern.

Rev Date: 05/29/20

SV11190C Calabasas High Field LP



Existing Conditions



Proposed Site Build

View: 1
Revision Date: 05/29/20



PHOTOGRAPHIC VISUALIZATIONS CREATED BY



SV11190C Calabasas High Field LP



Existing Conditions



Proposed Site Build

View: 2
Revision Date: 05/29/20



SV11190C Calabasas High Field LP



Existing Conditions

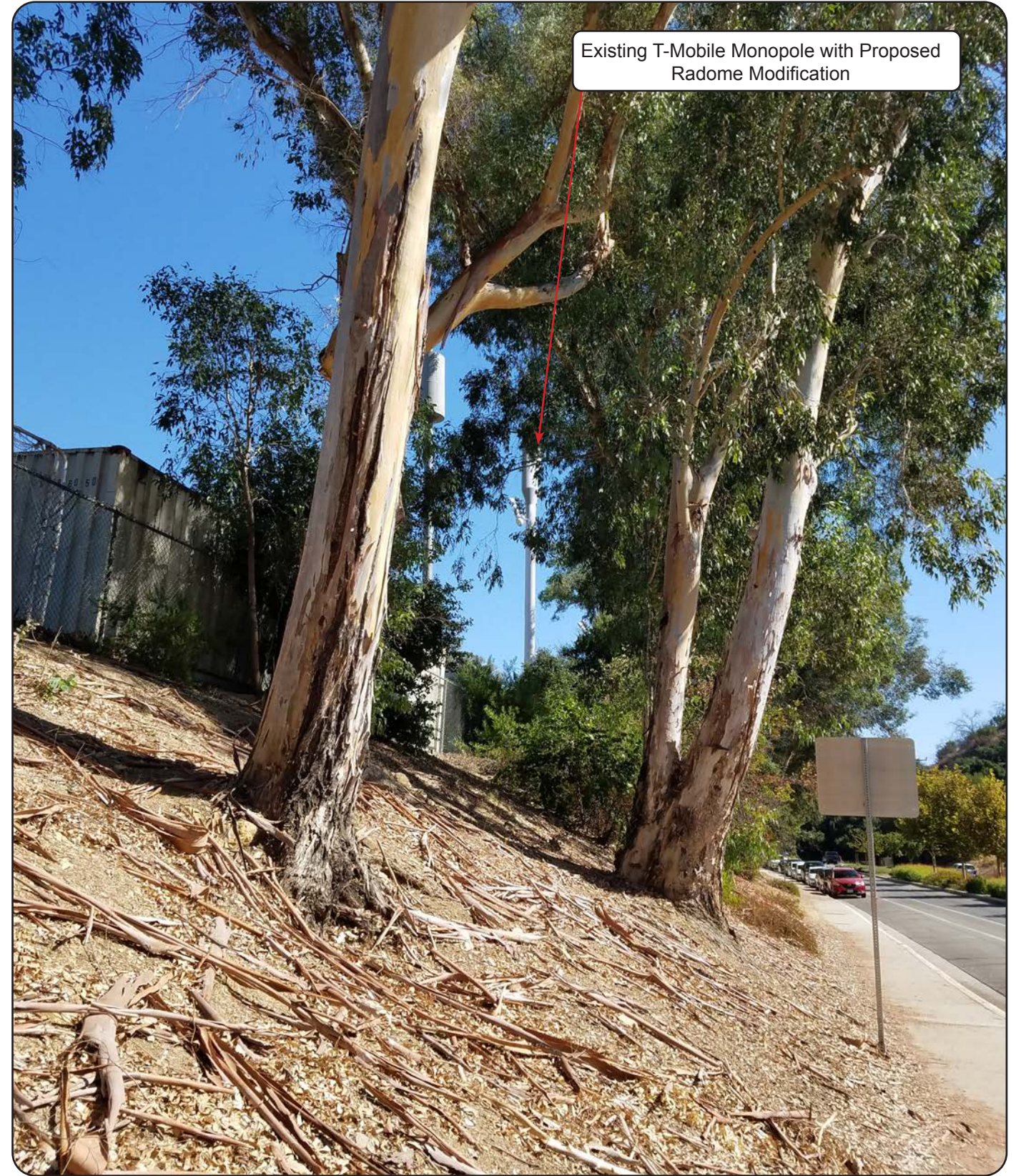

Proposed Site Build

SV11190C Calabasas High Field LP



Existing Conditions

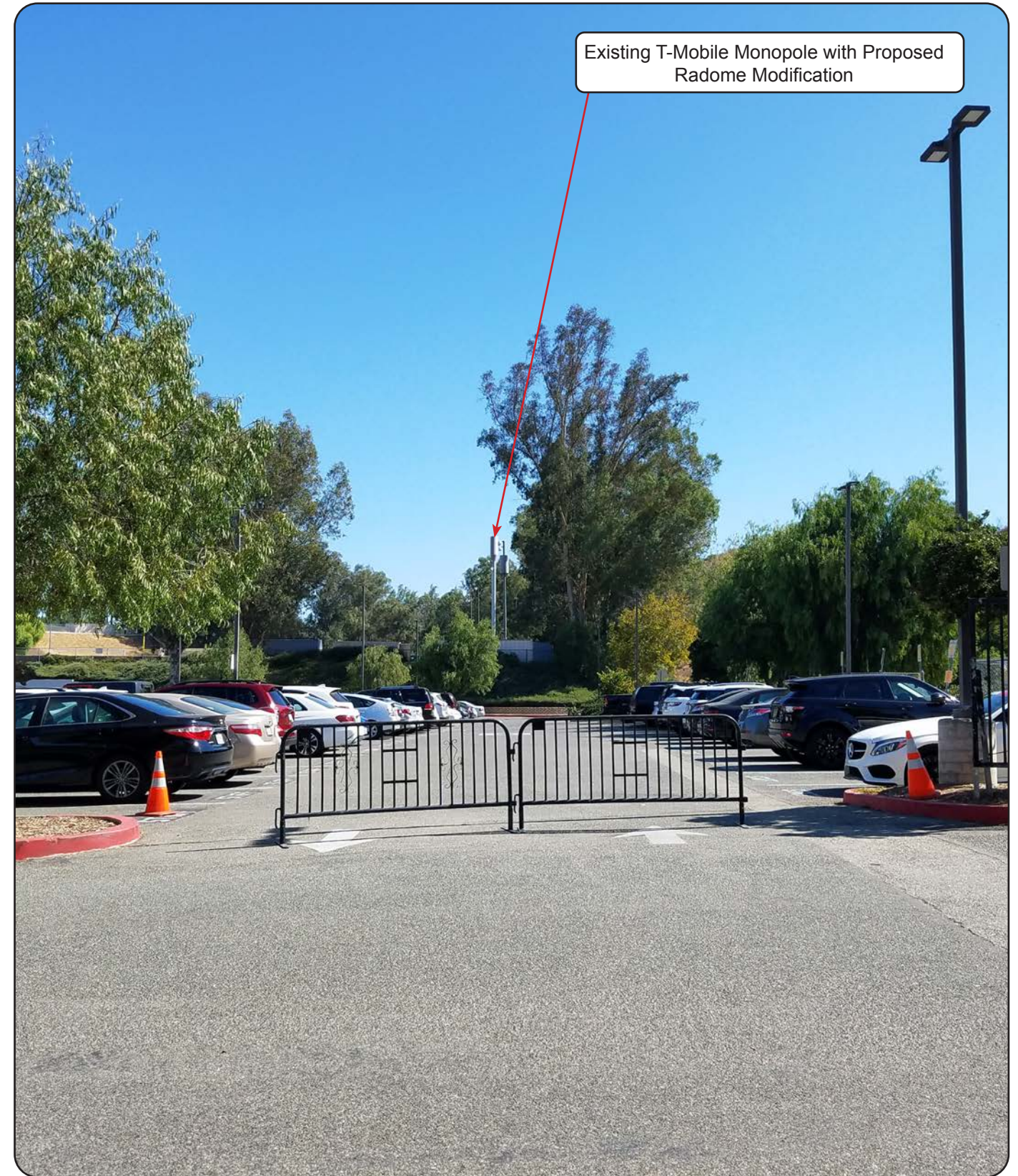

Proposed Site Build

View: 4
Revision Date: 05/29/20

Synergy a Division of
Advantage Engineers
www.synergy.cc

PHOTOGRAPHIC VISUALIZATIONS CREATED BY

EST. 2019

ASCEND
SOUTH WEST
www.ascendsouthwest.com



4100 Guardian St., Suite 101
Simi Valley, CA 93063